

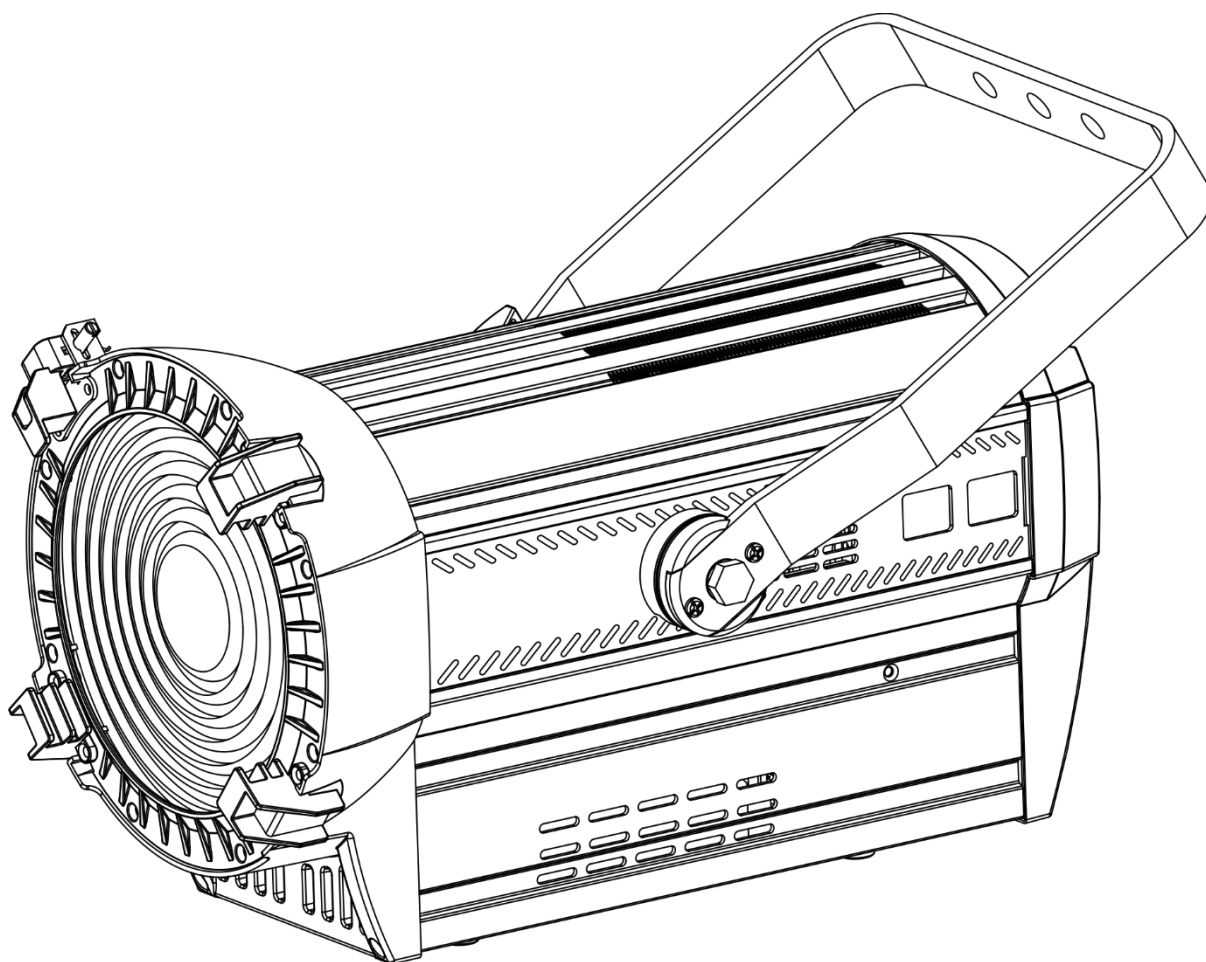

MANUAL



ENGLISH

Performer 2000 RGBAL

V1

Ordercode: 33038

Table of contents

Warning3
Safety Instructions3
Operating Determinations5
Rigging5
Connection with the mains6
Return Procedure7
Claims7

Description of the device8
Features8
Frontside8
Backside9

Installation9

Set Up and Operation9
Color Frame Retaining Clip10
Setting the Angle10
Control Modes11
 One Performer (Stand-alone)11
 Multiple Performers (Master/Slave control)11
 Multiple Performers (DMX Control)12
Fixture Linking13
Data Cabling13
Control Panel14
Control Mode14
DMX Addressing14
Menu Overview15
Main Menu Options16
 1. Manual Mode16
 1.1. Mode 117
 1.2. Mode 217
 1.3. Mode 317
 1.4. Mode 418
 2. Static18
 3. Preset Colors19
 4. Address19
 5. Run Mode20
 6. Personality20
 7. Setting20
 7.1. Upload21
 7.2. Reset21
 7.3. Color21
 7.4. Dimmer21
 7.5. DMX Error22
 7.6. Performance22
 7.7. MCON (DMX data transfer)22
 7.8. PWM Rate (refresh rate)23
 7.9. Power CCT (correlated color temperature)23
 8. Key23
 9. Calibration.C24
 9.1. White24
 9.2. RGBtoW24
 9.3. Calibration.R (reset)24
 10. Info25
 10.1. Version25
 10.2. RDM25

DMX Channels25
 8 channels (HSIC)25
 10 channels (SSP)26
 13 channels (TOUR)27
 19 channels (TR16)29

Cleaning31
 Cleaning the Glass Lens31

Maintenance32
 Replacing the Fuse32

Troubleshooting32
 No Light32
 No Response to DMX.....33

Product Specifications34

Dimensions35

Notes36

Warning



**For your own safety, please read this user manual carefully
before your initial start-up!**



Unpacking Instructions

Immediately upon receiving this product, carefully unpack the carton and check the contents to ensure that all parts are present, and have been received in good condition. Notify the dealer immediately and retain packing material for inspection if any parts appear damaged from shipping or the carton itself shows signs of mishandling. Save the carton and all packing materials. In the event that a fixture must be returned to the factory, it is important that the fixture be returned in the original factory box and packing.

Your shipment includes:

- Showtec Performer 2000 RGBAL
- Pro power cable (1,5 m)
- 1 x safety cable
- User manual

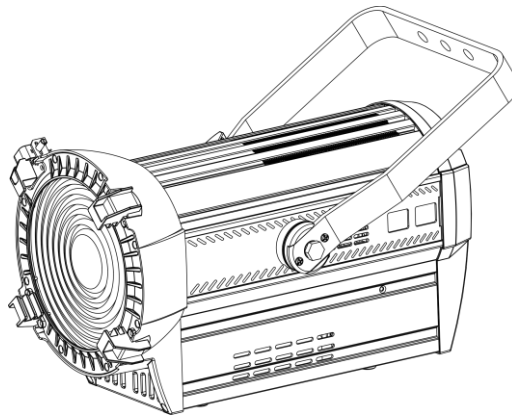

LED Expected Lifespan

LEDs gradually decline in brightness over time. HEAT is the dominant factor that leads to the acceleration of this decline. Packaged in clusters, LEDs exhibit higher operating temperatures than in ideal or singular optimum conditions. For this reason, when all color LEDs are used at their fullest intensity, life of the LEDs is significantly reduced. If improving the lifespan is of higher priority, place care in providing for lower operational temperatures. This may include climatic-environmental and the reduction of overall projection intensity.



CAUTION!

**Keep this device away from rain and moisture!
Unplug mains lead before opening the housing!**



Safety Instructions

Every person involved with the installation, operation and maintenance of this device has to:

- be qualified
- follow the instructions of this manual



**CAUTION! Be careful with your operations.
With a dangerous voltage you can suffer
a dangerous electric shock when touching the wires!**



Before the initial start-up, please make sure that there is no damage caused by transportation. Should there be any, consult your dealer and do not use the device.

To maintain perfect condition and to ensure a safe operation, it is absolutely necessary for the user to follow the safety instructions and warning notes contained in this manual.

Please consider that damages caused by manual modifications to the device are not subject to warranty. This device contains no user-serviceable parts. Refer servicing to qualified technicians only.

IMPORTANT:

The manufacturer will not accept liability for any resulting damages caused by the non-observance of this manual or any unauthorized modification to the device.

- Never let the power cord come into contact with other cables! Handle the power cord and all connections with the mains with particular caution!
- Never remove warning or informative labels from the unit.
- Never use anything to cover the ground contact.
- Never lift the fixture holding it by the projector-head, as the mechanics may be damaged. Always hold the fixture by the transport handles.
- Never place any material over the lens.
- Never look directly into the light source.
- Never leave any cables lying around.
- Do not insert objects into air vents.
- Do not connect this device to a dimmer pack.
- Do not switch the device on and off in short intervals, as this will reduce the device's life.
- Do not touch the device's housing bare-handed during its operation (housing becomes very hot). Allow the fixture to cool for at least 5 minutes before handling.
- Do not shake the device. Avoid brute force when installing or operating the device.
- Only use the device indoors, avoid contact with water or other liquids.
- Only operate the fixture after having checked if the housing is firmly closed and all screws are tightly fastened.
- Only operate the device after having familiarized with its functions.
- Avoid flames and do not put close to flammable liquids or gases.
- Always keep the case closed while operating.
- Always allow a free air space of at least 50 cm around the unit for ventilation.
- Always disconnect power from the mains, when device is not used or before cleaning! Only handle the power cord holding it by the plug. Never pull out the plug by tugging the power cord.
- Make sure that the device is not exposed to extreme heat, moisture or dust.
- Make sure that the available voltage is not higher than stated on the rear panel.
- Make sure that the power cord is never crimped or damaged. Check the device and the power cord from time to time.
- If the lens is obviously damaged, it has to be replaced.
- If device was dropped or struck, disconnect mains power supply immediately. Have a qualified engineer inspect for safety before operating.
- If the device has been exposed to drastic temperature fluctuation (e.g. after transportation), do not switch it on immediately. The arising condensation water might damage your device. Leave the device switched off until it has reached room temperature.
- If your Showtec device fails to work properly, discontinue the use immediately. Pack the unit securely (preferably in the original packing material), and return it to your Showtec dealer for service.
- For adult use only. Never leave the unit running unattended.
- Never attempt to bypass the thermostatic switch or fuses.
- For replacement use fuses of same type and rating only.
- The user is responsible for correct positioning and operating of the Performer. The manufacturer will not accept liability for damages caused by the misuse or incorrect installation of this device.
- This device falls under protection class I. Therefore it is essential to connect the yellow/green conductor to earth.
- Repairs, servicing and electric connection must be carried out by a qualified technician.
- **WARRANTY:** Till one year after date of purchase.



CAUTION! Eyedamages!!!
Avoid looking directly into the lightsource!!!
(meant especially for epileptics)!!!



Operating Determinations

- This device is not designed for permanent operation. Consistent operation breaks will ensure that the device will serve you for a long time without defects.
- The minimum distance between light output and the illuminated surface must be bigger than 1 meter.
- To eliminate wear and improve lifespan, during periods of non-use, completely disconnect from power via breaker or by unplugging.
- The maximum ambient temperature $t_a = 40^\circ\text{C}$ must never be exceeded.
- The relative humidity must not exceed 50 % with an ambient temperature of 40°C .
- If this device is operated in any other way than the one described in this manual, the product may suffer damages and the warranty becomes void.
- Any other operation may lead to dangers like short-circuit, burns, electric shock, crash, etc.

You endanger your own safety and the safety of others!

Rigging

Please follow the European and national guidelines concerning rigging, trussing and all other safety issues.

Do not attempt the installation yourself !

Always let the installation be carried out by an authorized dealer !

Procedure:

- If the Performer is lowered from the ceiling or high joists, professional trussing systems have to be used.
- Use a clamp to mount the Performer, with the mounting bracket, to the trussing system.
- The Performer must never be fixed swinging freely in the room.
- The installation must always be secured with a safety attachment, e.g. an appropriate safety net or safety cable.
- When rigging, derigging or servicing the Performer, always make sure, that the area below the installation site is secured and that there are not any unauthorized people around.

Improper installation can cause serious injuries and/or damage of property!

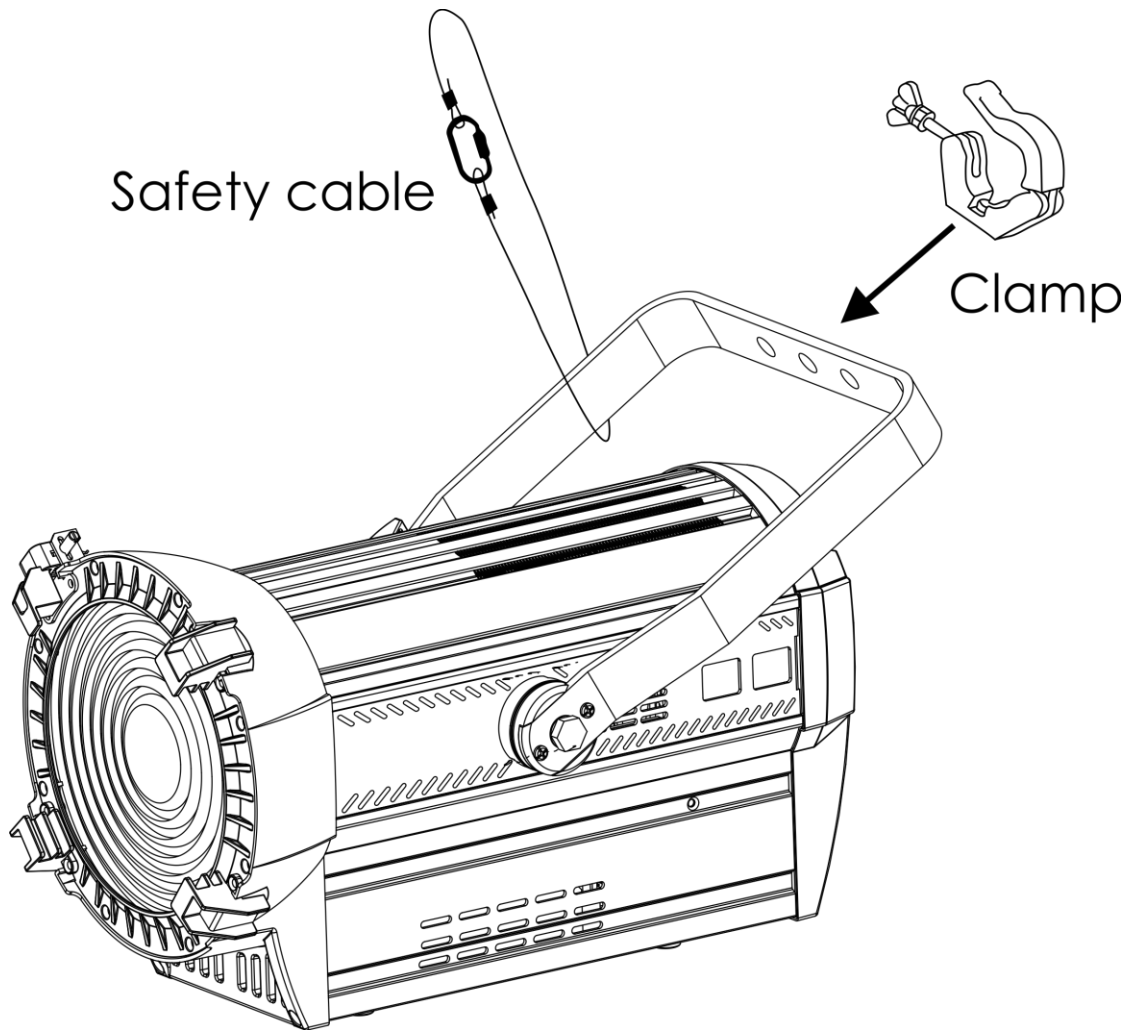

Connection with the mains

Connect the device to the mains with the power-plug.
 Always check if the right color cable is connected to the right place.

International	EU Cable	UK Cable	US Cable	Pin
L	BROWN	RED	YELLOW/COPPER	PHASE
N	BLUE	BLACK	SILVER	NEUTRAL
⊕	YELLOW/GREEN	GREEN	GREEN	PROTECTIVE GROUND

Make sure that the device is always properly connected to the earth!

Improper installation can cause serious injuries and/or damage of property!



Return Procedure

Returned merchandise must be sent prepaid and in the original packing, call tags will not be issued. Package must be clearly labeled with a Return Authorization Number (RMA number). Products returned without an RMA number will be refused. Highlite will not accept the returned goods or any responsibility. Call Highlite 0031-455667723 or mail offersales@highlite.nl and request an RMA prior to shipping the fixture. Be prepared to provide the model number, serial number and a brief description of the cause for the return. Be sure to properly pack fixture, any shipping damage resulting from inadequate packaging is the customer's responsibility. Highlite reserves the right to use its own discretion to repair or replace product(s). As a suggestion, proper UPS packing or double-boxing is always a safe method to use.

Note: If you are given an RMA number, please include the following information on a piece of paper inside the box:

- 01) Your name
- 02) Your address
- 03) Your phone number
- 04) A brief description of the symptoms

Claims

The client has the obligation to check the delivered goods immediately upon delivery for any shortcomings and/or visible defects, or perform this check after our announcement that the goods are at their disposal. Damage incurred in shipping is the responsibility of the shipper; therefore the damage must be reported to the carrier upon receipt of merchandise.

It is the customer's responsibility to report and submit claims with the shipper in the event that a fixture is damaged due to shipping. Transportation damage has to be reported to us within one day after receipt of the delivery.

Any return shipment has to be made post-paid at all times. Return shipments must be accompanied with a letter defining the reason for return shipment. Non-prepaid return shipments will be refused, unless agreed otherwise in writing.

Complaints against us must be prepared in writing or sent by fax within 10 working days after receipt of the invoice. After this period complaints will not be handled anymore.

Complaints will only then be considered if the client has so far complied with all parts of the agreement, regardless of the agreement from which the obligation is resulting.

Description of the device

Features

The Showtec Performer 2000 RGBAL is a theater spotlight with high output and great effects.

- Input voltage: 100-240V AC, 50/60Hz
- Power consumption: 230W
- Light source: 1 x 240W LED Array 5-in-1
- Drive current: 1,5A
- Refresh rate: 600Hz to 25kHz
- Light output: 55000 Lux @1m (15° zoom)
- Max flux: 5300 Lumen
- Peak intensity: 41900 cd
- Color rendering: >90Ra (2700-4500K), >85Ra (5600-8000K)
- Color temperature: 2700-8000K
- Dimmer: 0-100%
- Dimming curves: Dimm4 technology, 4 presets
- Dimmer resolution: 16bit
- Strobe: 0-25Hz
- Control protocol: RDM, DMX-512
- DMX channels: 8, 10, 13, 19 channels
- Motorized zoom: 15-45°
- Field angle: 25-76°
- Control modes: Stand-alone, Master/Slave, DMX-512/RDM
- Connections: 3-pin/5-pin XLR signal connectors IN/OUT, Pro power connectors Blue IN/Gray OUT
- Housing: Extruded aluminum & flame retardant plastic
- Color: Black
- Cooling: Internal fan
- IP rating: IP20
- Fuse: T6,3AL/250V
- Dimensions: 455 x 285 x 435 mm (LxWxH)
- Weight: 7,5 kg

Optional accessories

[33041](#) – Barndoor Performer 2000

[33042](#) – Filter Frame Performer 2000

Frontside

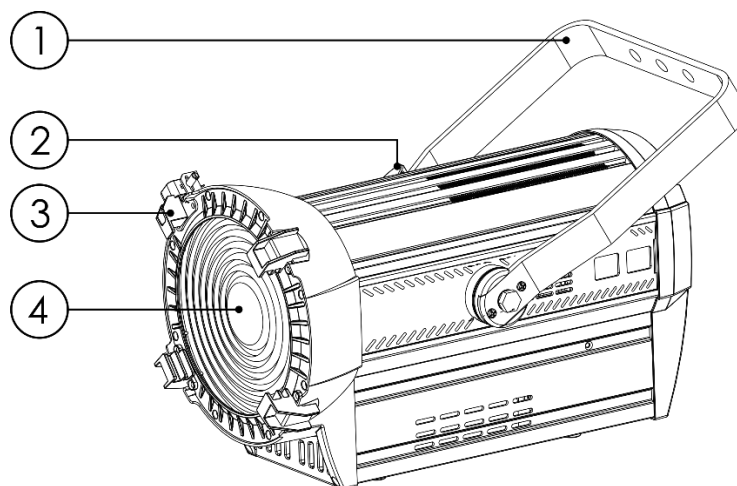

Fig. 01

- 01) Mounting bracket
- 02) Adjustment screw
- 03) Color frame retaining clip
- 04) Lens

Backside

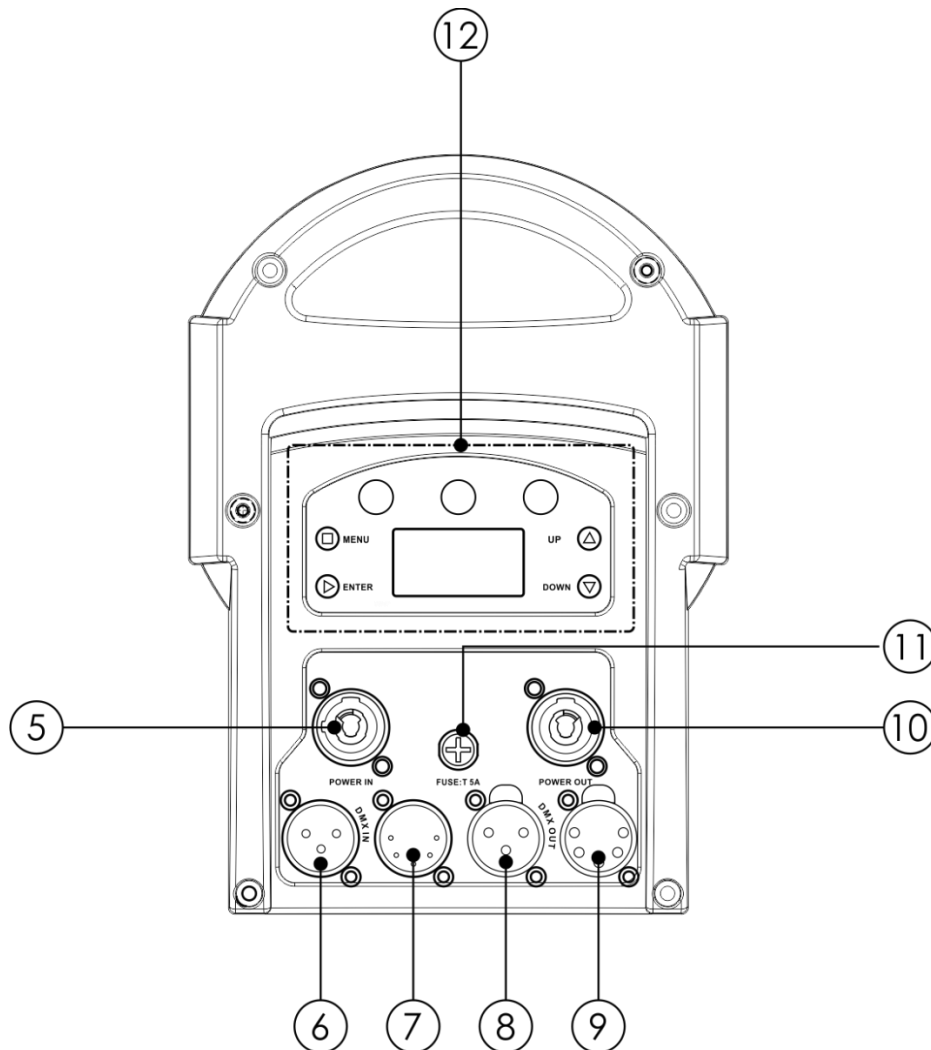

Fig. 02

- 05) 100-240V Pro power connector Blue IN
- 06) 3-pin DMX signal connector IN
- 07) 5-pin DMX signal connector IN
- 08) 3-pin DMX signal connector OUT
- 09) 5-pin DMX signal connector OUT
- 10) 100-240V Pro power connector Gray OUT
- 11) Fuse T6,3AL/250V
- 12) LCD display + control buttons

Installation

Remove all packing materials from the Performer 2000 RGBAL. Check if all foam and plastic padding is removed. Connect all cables.

Do not supply power before the whole system is set up and connected properly.

Always disconnect from electric mains power supply before cleaning or servicing.

Damages caused by non-observance are not subject to warranty.

Set Up and Operation

Follow the directions below, as they pertain to your preferred operation mode.

Before plugging the unit in, always make sure that the power supply matches the product specification voltage. Do not attempt to operate a 120V specification product on 230V power, or vice versa.

Connect the device to the main power supply.

Color Frame Retaining Clip

The color frame holder is equipped with a spring-loaded retaining clip. This prevents color frames and accessories from falling out.



Make sure that all color frame accessories are locked in position with the retaining clip before hanging the Performer 2000 RGBAL.



- 01) Release the retaining clip by pressing the lock towards the lens and pressing the longer side of the screw. The retaining clip will open.
- 02) Insert the color frame(s).
- 03) Lock the retaining clip by pressing the retaining clip towards the lens.

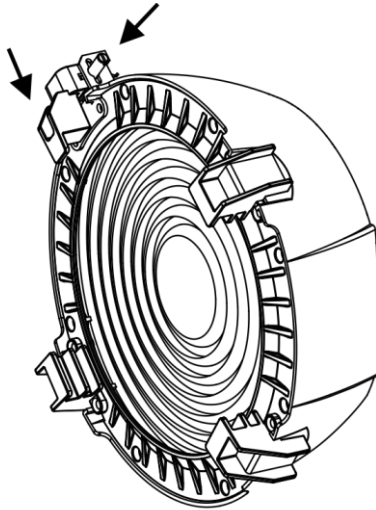

Retaining clip in unlocked position

Fig. 03

Setting the Angle

- 01) Loosen the adjustment screw (do not remove it).
- 02) Tilt the fixture to the desired position.
- 03) Tighten the adjustment screw to secure the fixture in position.

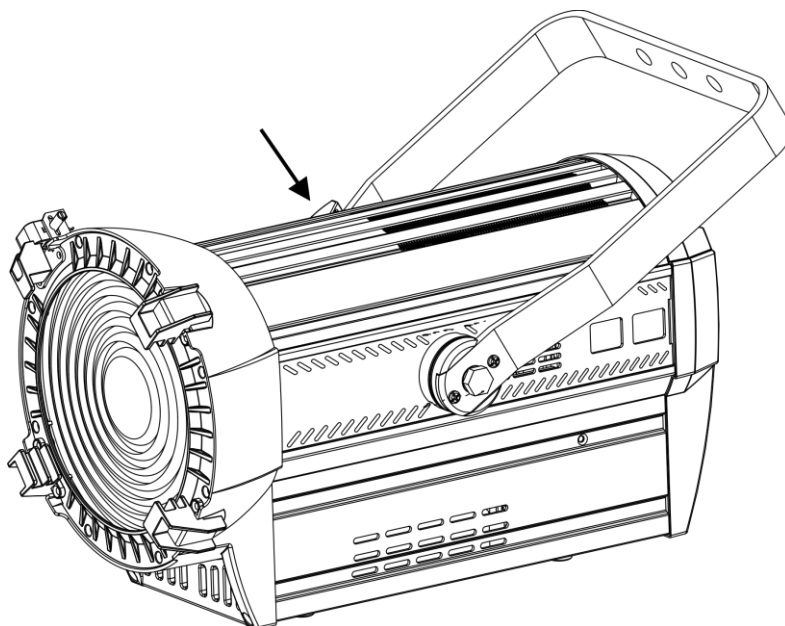

Fig. 04

Control Modes

There are 3 modes:

- Stand-alone
- Master/Slave
- RDM/DMX-512 (8CH, 10CH, 13CH, 19CH)

One Performer (Stand-alone)

- 01) Fasten the effect light to a firm trussing. Leave at least 0,5 meter on all sides for air circulation.
- 02) Plug the end of the electric mains power cord into a proper electric power supply socket.
- 03) When the Performer is not connected with a DMX cable, it functions as a stand-alone device. Please see pages 16-25 for more information.

Multiple Performers (Master/Slave control)

- 01) Fasten the effect light onto firm trussing. Leave at least 0,5 meter on all sides for air circulation.
- 02) Use a 3-pin/5-pin XLR cable to connect the Performer.

The pins:



- 01) Earth
- 02) Signal -
- 03) Signal +

- 03) Link the units as shown in fig. 05. Connect the first unit's DMX "out" socket with the second unit's "in" socket, using a DMX-signal cable. Repeat this process to link the second, third, and fourth units. You can use the same functions on the master device as described on pages 16-25. This means that you can set your desired operation mode on the master device and all slave devices will react the same as the master device.

Multiple Performers (Master/Slave control)

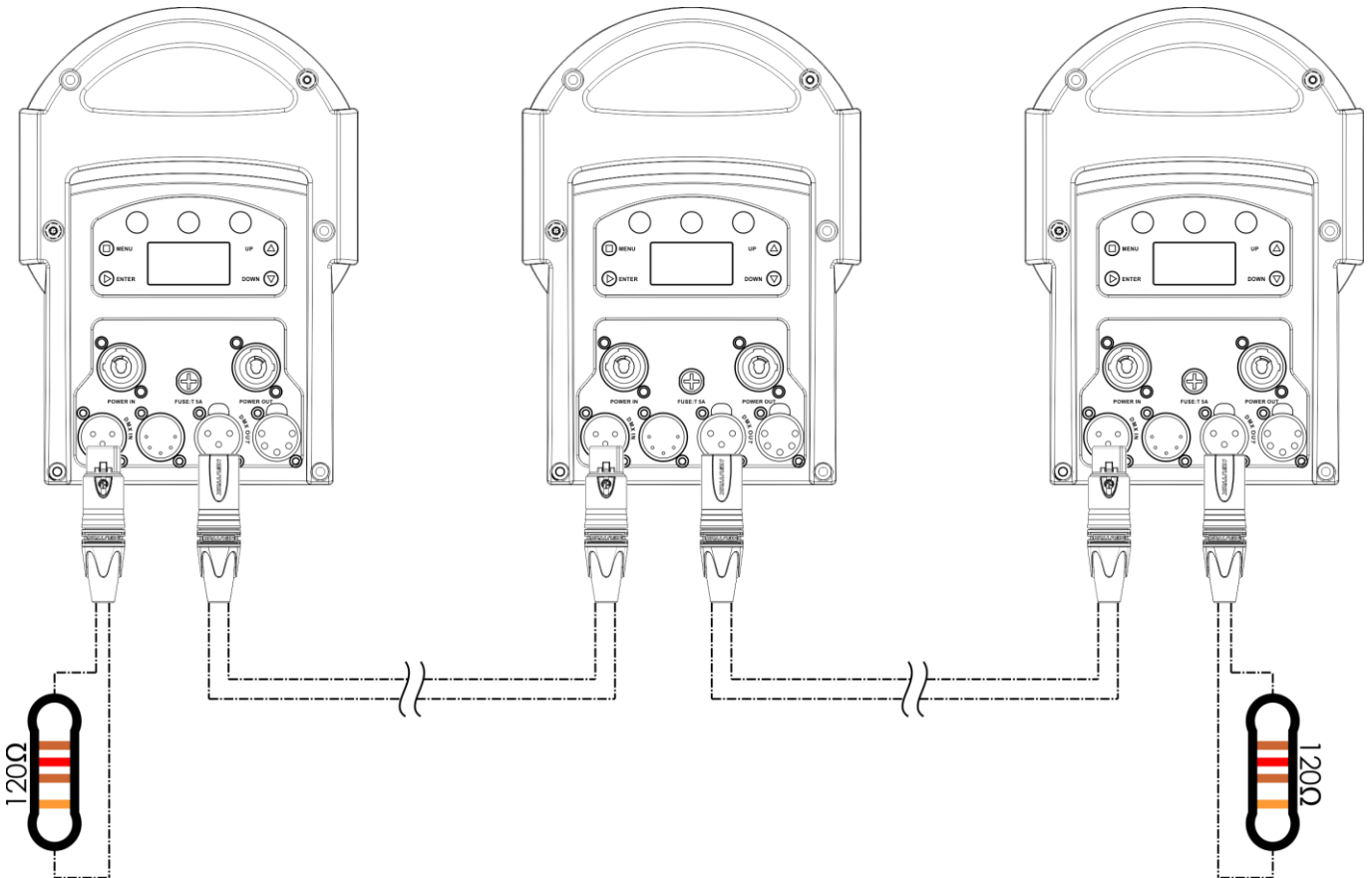
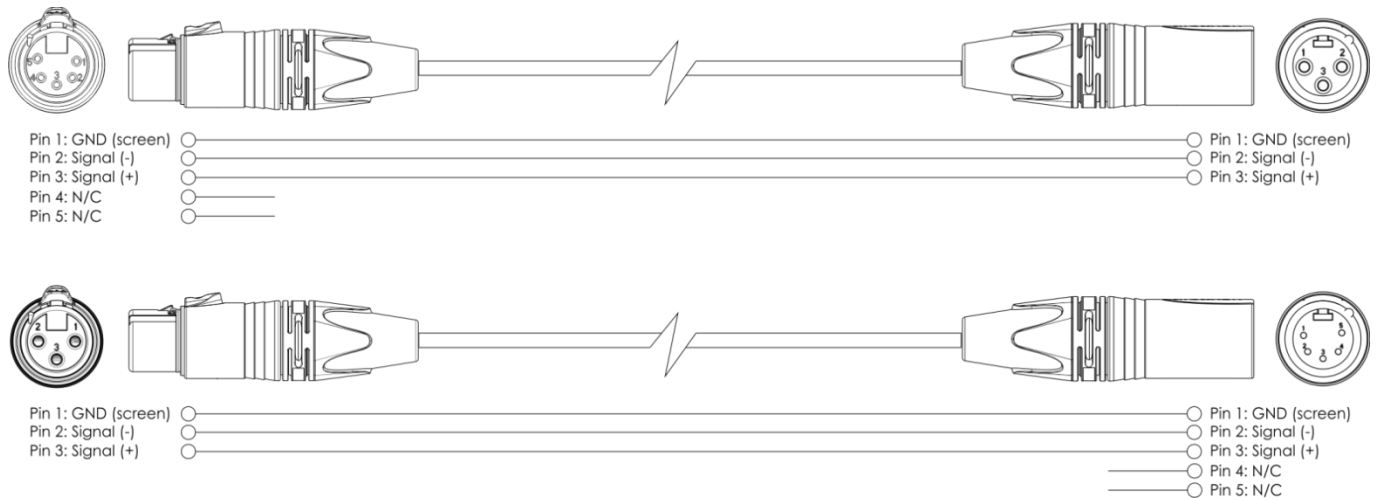

Fig. 05

Multiple Performers (DMX Control)

- 01) Fasten the effect light to a firm trussing. Leave at least 0,5 meter on all sides for air circulation.
- 02) Always use a safety cable (ordercode 70140 / 70141).
- 03) Use a 3-pin/5-pin XLR cable to connect the Performers and other devices.



- 04) Link the units as shown in fig. 06. Connect the first unit's DMX "out" socket with the second unit's "in" socket, using a DMX-signal cable. Repeat this process to link the second, third, and fourth units.
- 05) Supply electric power: Plug electric mains power cords into each unit's Pro power socket, then plug the other end of the mains power cord into proper electric power supply sockets, starting with the first unit. Do not supply power before the whole system is set up and connected properly.

Multiple Performers DMX Set Up

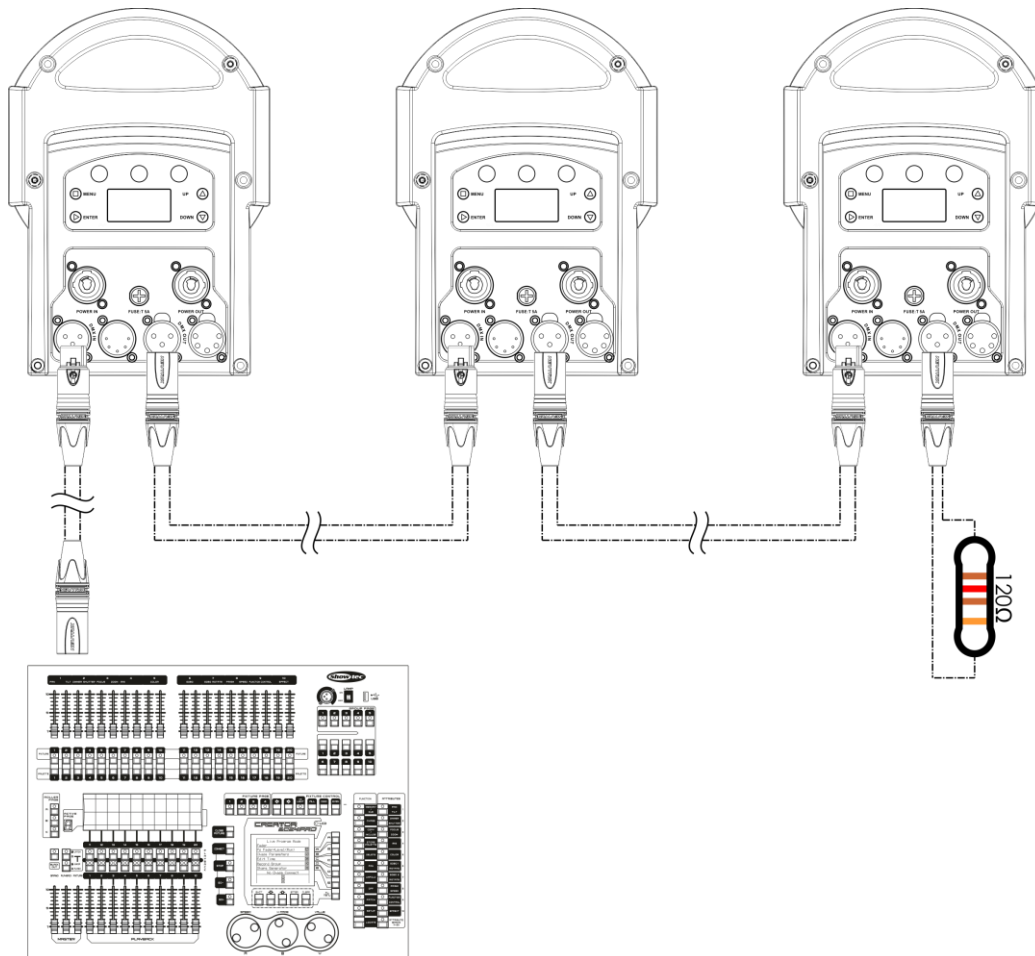



Fig. 06

Note : Link all cables before connecting electric power

Fixture Linking

You will need a serial data link to run light shows of one or more fixtures using a DMX-512 controller or to run synchronized shows of two or more fixtures set to a master/slave operating mode. The combined number of channels required by all the fixtures on a serial data link determines the number of fixtures the data link can support.

Important: Fixtures on a serial data link must be daisy-chained in a single line. To comply with the EIA-485 standard, no more than 30 devices should be connected on one data link. Connecting more than 30 fixtures on one serial data link without the use of a DMX optically isolated splitter may result in deterioration of the digital DMX signal.

 Maximum recommended DMX data link distance: 100 meters
Maximum recommended number of fixtures on a DMX data link: 30 fixtures
Maximum recommended number of fixtures on a power link @110V: 4 fixtures
Maximum recommended number of fixtures on a power link @230V: 8 fixtures

Data Cabling

To link fixtures together, you must obtain data cables. You can purchase DAP Audio certified DMX cables directly from a dealer/distributor or construct your own cable. If you choose to create your own cable, please use data-grade cables that can carry a high quality signal and are less prone to electromagnetic interference.

DAP Audio DMX Data Cables

- DAP Audio Basic microphone cable for allround use. bal. XLR/M 3-pin > XLR/F 3-pin. **Ordercode** FL01150 (1,5 m), FL013 (3 m), FL016 (6 m), FL0110 (10 m), FL0115 (15 m), FL0120 (20 m).
- DAP Audio X-type data cable XLR/M 3-pin > XLR/F 3-pin. **Ordercode** FLX0175 (0,75 m), FLX01150 (1,5 m), FLX013 (3 m), FLX016 (6 m), FLX0110 (10 m).
- DAP Audio cable for the demanding user with exceptional audio-qualities and connector made by Neutrik®. **Ordercode** FL71150 (1,5 m), FL713 (3 m), FL716 (6 m), FL7110 (10 m).
- DAP Audio cable for the demanding user with exceptional audio-qualities and connector made by Neutrik®. **Ordercode** FL7275 (0,75 m), FL72150 (1,5 m), FL723 (3 m), FL726 (6 m), FL7210 (10 m).
- DAP Audio 110 Ohm cable with digital signal transmission. **Ordercode** FL0975 (0,75 m), FL09150 (1,5 m), FL093 (3 m), FL096 (6 m), FL0910 (10 m), FL0915 (15 m), FL0920 (20 m).

The Performer 2000 RGBAL can be operated with a controller in **control mode** or without the controller in **stand-alone mode**.

Control Panel

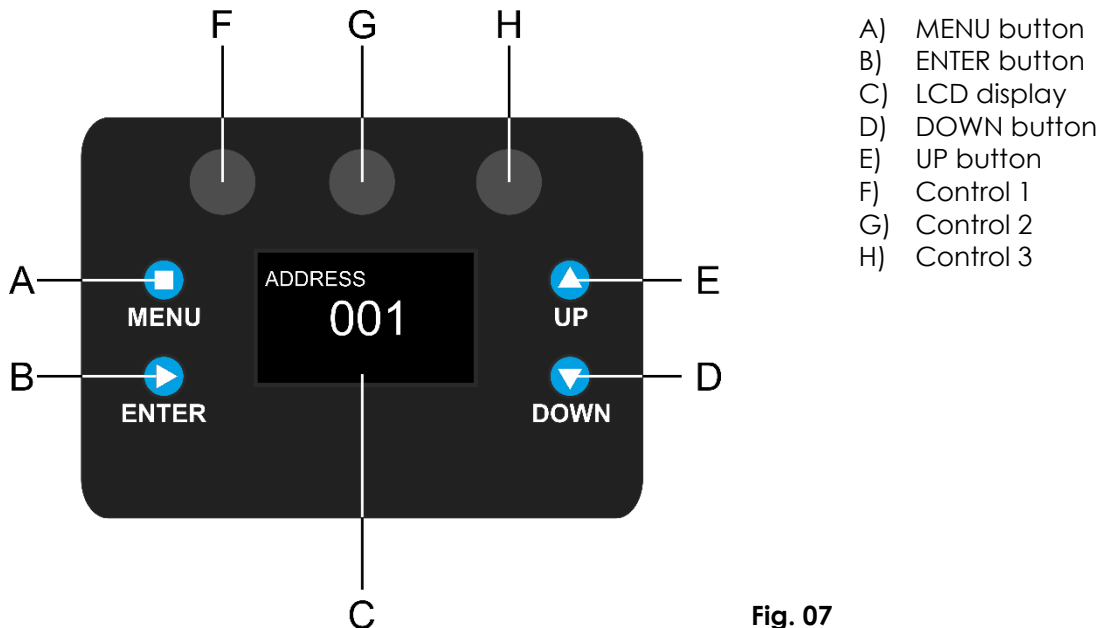

Fig. 07

Control Mode

The fixtures are individually addressed on a data-link and connected to the controller. The fixtures respond to the DMX signal from the controller. (When you select the DMX address and save it, the controller will display the saved DMX address, next time.)

DMX Addressing

The control panel on the front side of the base allows you to assign DMX fixture addresses, which is the first channel with which the Performer will respond to the controller.

Please note, when you use the controller, the unit has **19** channels.

When using multiple Performers, make sure you set the DMX addresses right.

Therefore, the DMX address of the first Performer should be **1(001)**; the DMX address of the second Performer should be **1+19=20 (020)**; the DMX address of the third Performer should be **20+19=39 (039)**, etc. Please, be sure that you do not have any overlapping channels in order to control each Performer correctly. If two or more Performers are addressed similarly, they will work similarly.

Controlling:

After having addressed all Performer fixtures, you may now start operating these via your lighting controller.

Note: After switching on, the Performer will automatically detect whether DMX 512 data is received or not. If there is no data received at the DMX-input, the "LED" on the control panel will not flash.

If not, the problem may be:

- The XLR cable from the controller is not connected with the input of the Performer 2000 RGBAL.
- The controller is switched off or defective, the cable or connector is defective, or the signal wires are swapped in the input connector.

Note: It is necessary to insert an XLR termination plug (with 120 Ohm) in the last fixture in order to ensure proper transmission on the DMX data link.

Display Off after 30 seconds

When no button is pressed for 30 seconds, the display will turn off.

To light up the display, you have to press the MENU, UP, DOWN or ENTER button. Once you have pressed the button, the display will light up.

Menu Overview

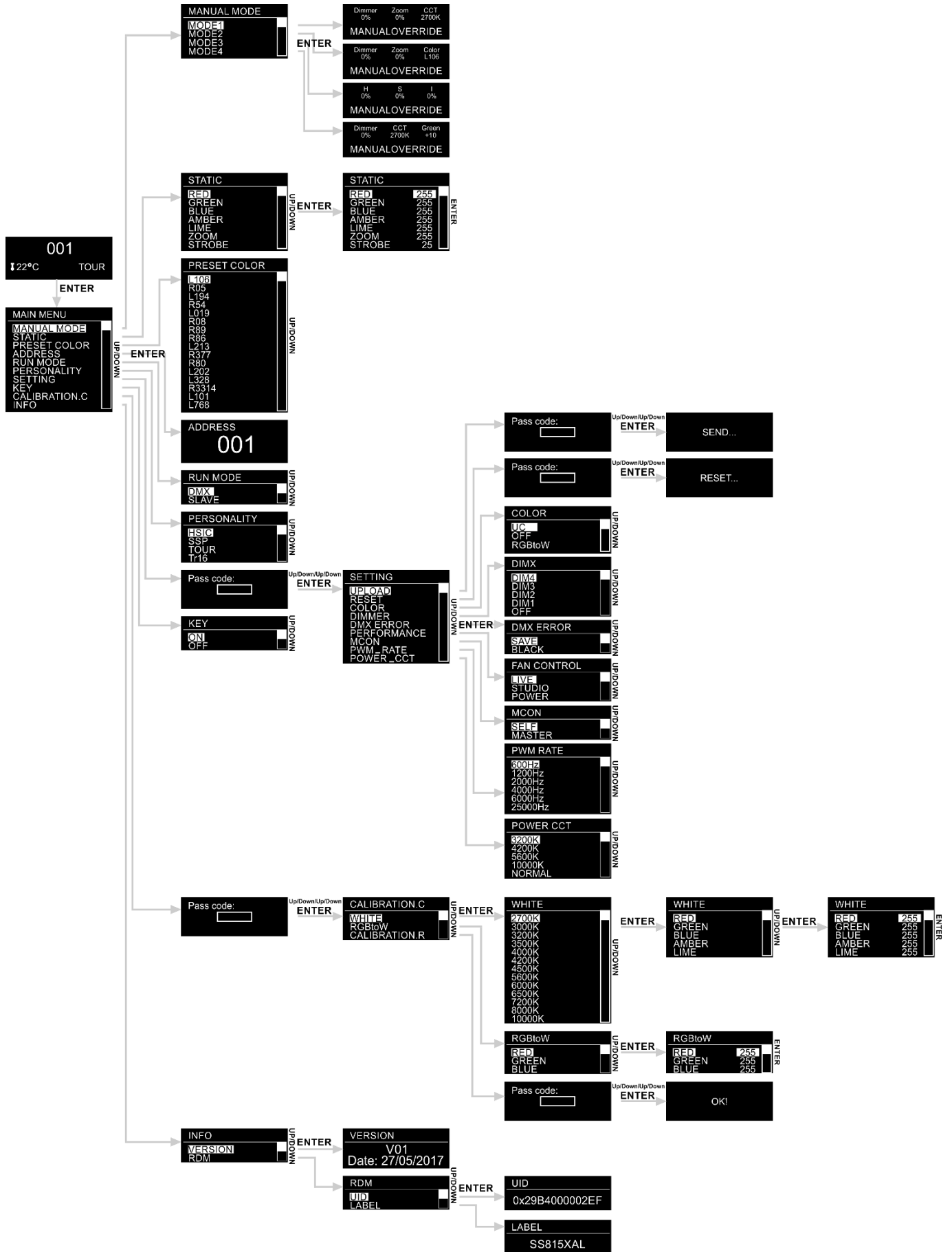

Main Menu Options

01) On start-up, the display will show information about the device's current status:

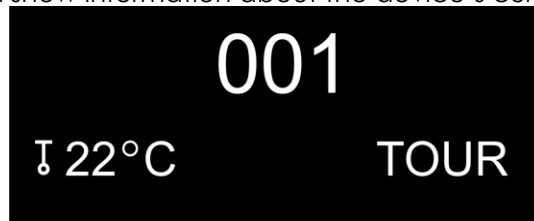

02) Press the **ENTER** button to open the main menu.

03) Press the **UP/DOWN** buttons to toggle through the 10 main menu options:

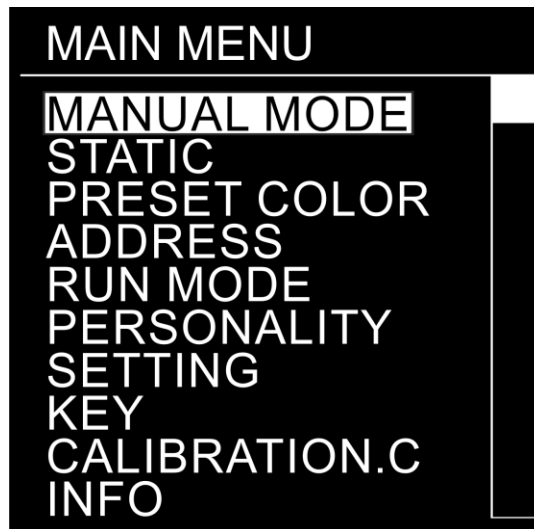

04) Press the **ENTER** button to open the desired submenu.

1. Manual Mode

In this menu you can set and adjust the desired manual mode.

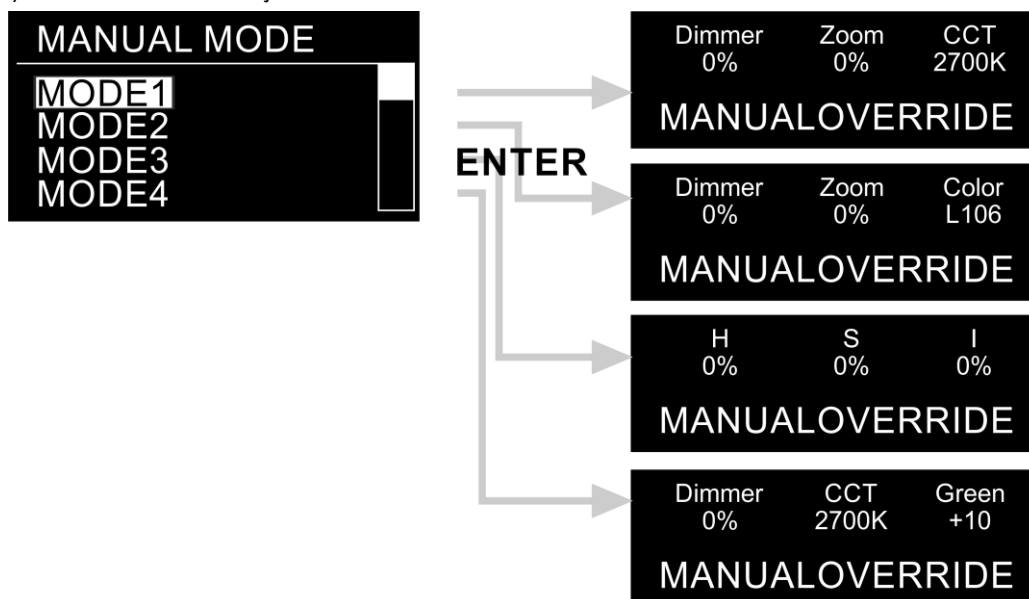

01) While in main menu, press the **UP/DOWN** buttons until the display shows **MANUAL MODE**.

02) Press the **ENTER** button to open the menu.

03) Press the **UP/DOWN** buttons to select the desired manual mode (1-4).

04) Press the **ENTER** button to activate the previously chosen mode.

1.1. Mode 1

In this menu you can set the dimmer, zoom and CCT.

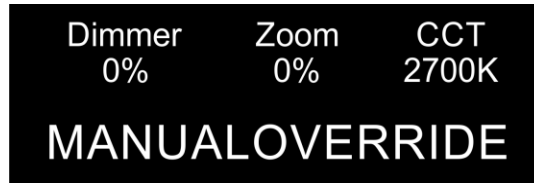

01) Turn the controls **(F/G/H)** to adjust settings.

02) The adjustment ranges are:

- **(F)** Dimmer: 0-100% (from dark to brightest)
- **(G)** Zoom: 0-100% (from small to big)
- **(H)** CCT: 2700K, 3000K, 3200K, 3500K, 4000K, 4200K, 4500K, 5600K, 6000K, 6500K, 7200K, 8000K

1.2. Mode 2

In this menu you can set the dimmer, zoom and choose a color preset.

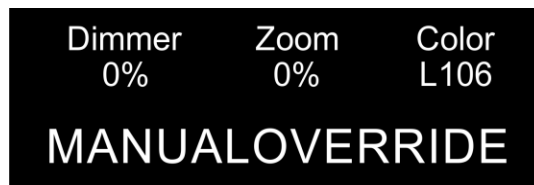

01) Turn the controls **(F/G/H)** to adjust settings.

02) The adjustment ranges are:

- **(F)** Dimmer: 0-100% (from dark to brightest)
- **(G)** Zoom: 0-100% (from small to big)
- **(H)** Color presets: L106, R05, L194, R54, L019, R08, R89, R86, L213, R377, R80, L202, L328, R3314, L101, L768

1.3. Mode 3

In this menu you can set the hue, saturation and intensity.



01) Turn the controls **(F/G/H)** to adjust settings.

02) The adjustment ranges are:

- **(F)** Hue: 0-100%
- **(G)** Saturation: 0-100%
- **(H)** Intensity: 0-100% (from dark to brightest)

1.4. Mode 4

In this menu you can set the dimmer, CCT and green.



01) Turn the controls (**F/G/H**) to adjust settings.

02) The adjustment ranges are:

- **(F)** Dimmer: 0-100% (from dark to brightest)
- **(G)** CCT: 2700K, 3000K, 3200K, 3500K, 4000K, 4200K, 4500K, 5600K, 6000K, 6500K, 7200K, 8000K
- **(H)** Green: -10 to +10

2. Static

In this menu you can manually set the colors, zoom and the strobe.

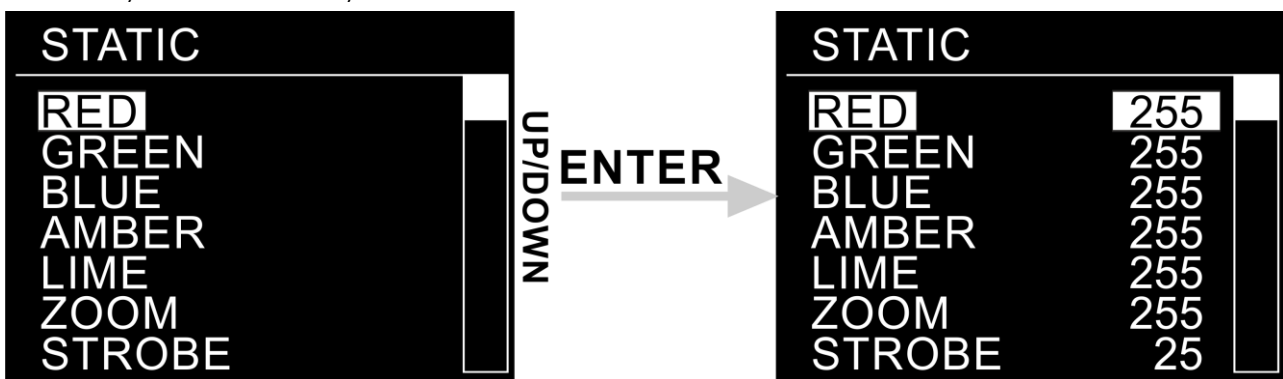

01) While in main menu, press the **UP/DOWN** buttons until the display shows **STATIC**.

02) Press the **ENTER** button to open the menu.

03) Press the **UP/DOWN** buttons to toggle through the 7 options:

- **RED** (0-255, from dark to brightest)
- **GREEN** (0-255, from dark to brightest)
- **BLUE** (0-255, from dark to brightest)
- **AMBER** (0-255, from dark to brightest)
- **LIME** (0-255, from dark to brightest)
- **ZOOM** (0-255, from small to big)
- **STROBE** (0-25, from low to high strobe frequency)

04) Press the **ENTER** button to open the desired option.

05) Press the **UP/DOWN** buttons to adjust settings.

06) Repeatedly press the **ENTER** button to toggle through the other available options and repeat step 5.

07) You can combine RED, GREEN, BLUE, AMBER and LIME to create an infinite range of colors (0-255).

3. Preset Colors

In this menu you can choose the desired color preset.

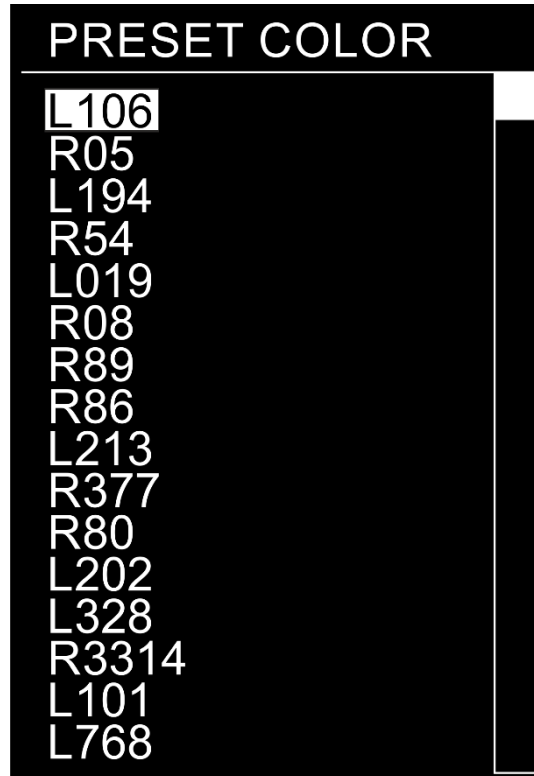

- 01) While in main menu, press the **UP/DOWN** buttons until the display shows **PRESET COLOR**.
- 02) Press the **ENTER** button to open the menu.
- 03) Press the **UP/DOWN** buttons to toggle through the 16 color presets: L106, R05, L194, R54, L019, R08, R89, R86, L213, R377, R80, L202, L328, R3314, L101, L768.

4. Address

In this menu you can set the desired DMX starting address.



- 01) While in main menu, press the **UP/DOWN** buttons until the display shows **ADDRESS**.
- 02) Press the **ENTER** button to open the menu.
- 03) Press the **UP/DOWN** buttons to set the desired DMX starting address. The adjustment range is between 001-512.

5. Run Mode

In this menu you can set the device as a master or slave.



- 01) While in main menu, press the **UP/DOWN** buttons until the display shows **RUN MODE**.
- 02) Press the **ENTER** button to open the menu.
- 03) Press the **UP/DOWN** buttons to toggle between the 2 options: **DMX** and **SLAVE**.
- 04) If the display shows **DMX**, the Performer will become a master device and will utilize the DMX protocol to determine its performance.
- 05) If the display shows **SLAVE**, the Performer will become a slave device and will react the same as the master device.

6. Personality

In this menu you can set the desired DMX channel mode (personality).



- 01) While in main menu, press the **UP/DOWN** buttons until the display shows **PERSONALITY**.
- 02) Press the **ENTER** button to open the menu.
- 03) Press the **UP/DOWN** buttons to toggle through the 4 channel modes:
 - **HSIC** 8-channel mode
 - **SSP** 10-channel mode
 - **TOUR** 13-channel mode
 - **TR16** 19-channel mode

7. Setting

In this menu you can adjust the device's special settings.

- 01) While in main menu, press the **UP/DOWN** buttons until the display shows **SETTING**.
- 02) Press the **ENTER** button to open the menu.
- 03) The display will show **PASS CODE** and you will need to insert a **key combination** which will **unlock this hidden menu**. To do so, **press the buttons in the following order: UP, DOWN, UP, DOWN, ENTER**.
- 04) Press the **UP/DOWN** buttons to toggle through the following options:
 - **UPLOAD**
 - **RESET**
 - **COLOR**
 - **DIMMER**
 - **DMX ERROR**
 - **PERFORMANCE**
 - **MCON**
 - **PWM_RATE**
 - **POWER_CCT**

7.1. Upload

In this menu you can send the custom programs to the slave devices.

- 01) When the display shows **UPLOAD**, press the **ENTER** button to open the menu.
- 02) The display will show **PASS CODE** and you will need to insert a **key combination** which will **unlock this hidden menu**. To do so, **press the buttons in the following order: UP, DOWN, UP, DOWN, ENTER**.
- 03) While **exporting**, the slave devices will light in **yellow**.
- 04) If there are any **problems with exporting**, the master and the slave devices will light in **red**.
- 05) If the operation was **completed successfully**, the master and the slave devices will light in **green**.

7.2. Reset

In this menu you can reset the settings.

- 01) When the display shows **RESET**, press the **ENTER** button to open the menu.
- 02) The display will show **PASS CODE** and you will need to insert a **key combination** which will **unlock this hidden menu**. To do so, **press the buttons in the following order: UP, DOWN, UP, DOWN, ENTER**.
- 03) The device will now reset its settings.

7.3. Color

In this menu you can set the color mixing.

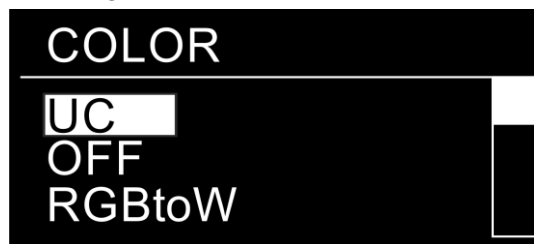

- 01) When the display shows **COLOR**, press the **ENTER** button to open the menu.
- 02) Press the **UP/DOWN** buttons to choose one of the 3 color mixing options:
 - **UC**: The RGB output is adjusted to a standard preset universal color. In this way, different Performer versions are color-balanced, in order to match each other.
 - **RGBtoW**: RGB = 255, 255, 255. The displayed color is the specific color which you have calibrated in Calibration menu (see page 24).
 - **OFF**: The RGB settings are: 255, 255, 255. The RGB values are not adjusted and the output is the most powerful.

7.4. Dimmer

In this menu you can set the dimmer speed.

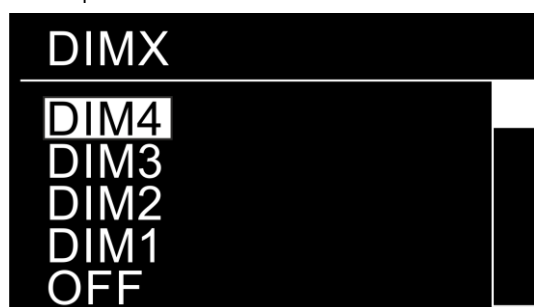

- 01) When the display shows **DIMMER**, press the **ENTER** button to open the menu.
- 02) Press the **UP/DOWN** buttons to toggle through the 5 options:
 - **OFF**: Dimmer speed is off
 - **DIM1-DIM4**: Dimmer speed, from fast to slow

7.5. DMX Error

In this menu you can determine what the device will do in case of a DMX signal error.



- 01) When the display shows **DMX ERROR**, press the **ENTER** button to open the menu.
- 02) Press the **UP/DOWN** buttons to toggle between the 2 options: **SAVE** and **BLACK**.
- 03) If the display shows **SAVE**, the Performer will utilize the last working DMX signal, which will ensure uninterrupted performance.
- 04) If the display shows **BLACK**, the Performer will black out.

7.6. Performance

In this menu you can set the performance of the cooling fan.



- 01) When the display shows **PERFORMANCE**, press the **ENTER** button to open the menu.
- 02) Press the **UP/DOWN** buttons to toggle through the 3 modes:
 - **LIVE**: Default mode. It provides a compromise between output quality and noise level.
 - **STUDIO**: Noise level-oriented mode. It emits little noise and operates at moderate power level.
 - **POWER**: Output-oriented mode. The device does not offer any consideration for noise level and operates at full power.

7.7. MCON (DMX data transfer)

In this menu you can set the DMX data transfer settings.



- 01) When the display shows **MCON**, press the **ENTER** button to open the menu.
- 02) Press the **UP/DOWN** buttons to toggle between the 2 options:
 - **SELF**: DMX data transfer OFF
 - **MASTER**: DMX data transfer ON

7.8. PWM Rate (refresh rate)

In this menu you can set the refresh rate.

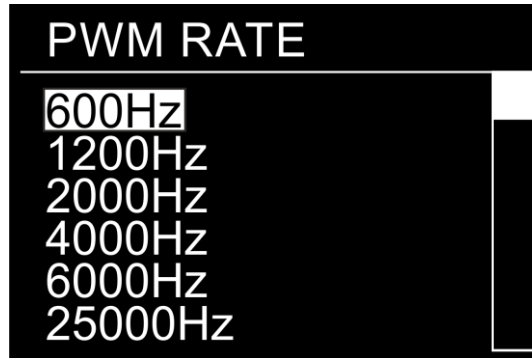

- 01) When the display shows **PWM_RATE**, press the **ENTER** button to open the menu.
- 02) Press the **UP/DOWN** buttons to toggle through the 6 options: 600Hz, 1200Hz, 2000Hz, 4000Hz, 6000Hz, 25000Hz.

7.9. Power CCT (correlated color temperature)

In this menu you can set the correlated color temperature.

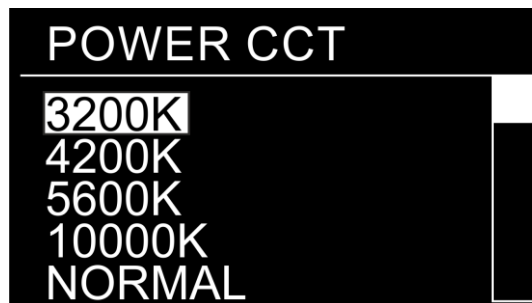

- 01) When the display shows **POWER_CCT**, press the **ENTER** button to open the menu.
- 02) Press the **UP/DOWN** buttons to toggle through the 5 options: 3200K, 4200K, 5600K, 10000K, NORMAL.

8. Key

In this menu you can set the safety lock.



- 01) While in main menu, press the **UP/DOWN** buttons until the display shows **KEY**.
- 02) Press the **ENTER** button to open the menu.
- 03) Press the **UP/DOWN** buttons to toggle between **ON** and **OFF** to activate/deactivate the safety lock.
- 04) When set to **ON**, you will need to insert the safety key combination every time the display turns off.
- 05) When set to **OFF**, the Settings menu will not get locked, providing that it was active when the display turned off. Otherwise, you will need to insert the key combination anyway.

9. Calibration.C

In this menu you can set the color calibration.

- 01) While in main menu, press the **UP/DOWN** buttons until the display shows **CALIBRATION.C**.
- 02) Press the **ENTER** button to open the menu.
- 03) The display will show **PASS CODE** and you will need to insert a **key combination** which will **unlock this hidden menu**. To do so, **press the buttons in the following order: UP, DOWN, UP, DOWN, ENTER**.

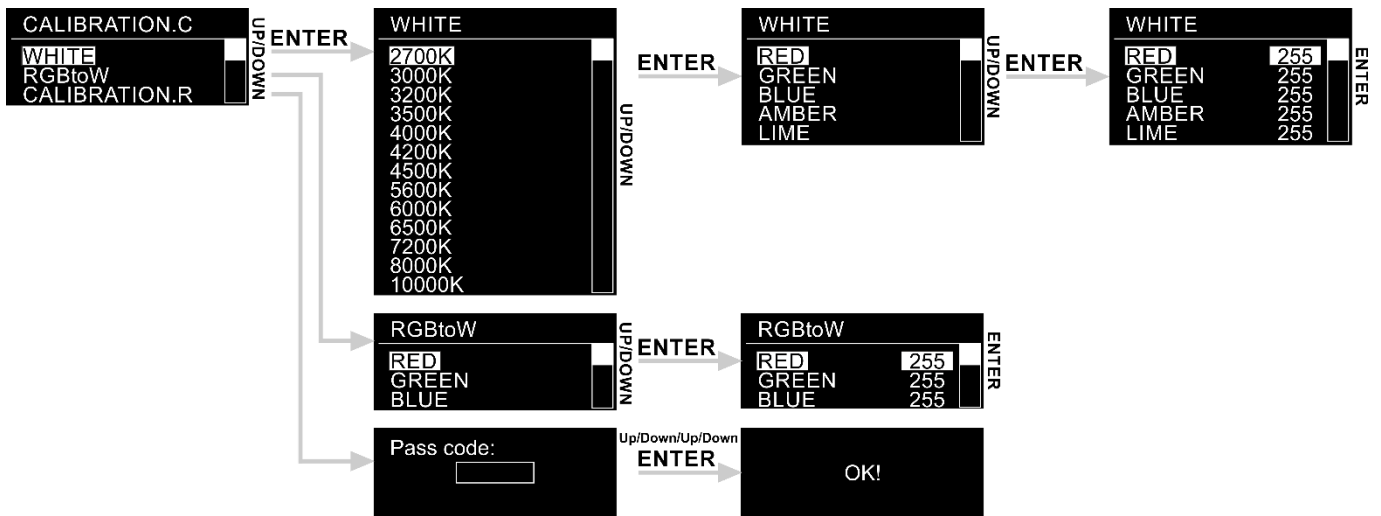

- 04) Press the **UP/DOWN** buttons to choose one of the 3 options:

- **WHITE**
- **RGBtoW**
- **CALIBRATION.R**

- 05) Press the **ENTER** button to open the desired menu.

9.1. White

- 01) Press the **UP/DOWN** buttons to choose one of the 13 white color presets (2700K-10000K).
- 02) Press the **ENTER** button to open the submenu.
- 03) Press the **UP/DOWN** buttons to toggle through RED, GREEN, BLUE, AMBER and LIME.
- 04) Press the **ENTER** button to choose the desired color.
- 05) Press the **UP/DOWN** buttons to increase/decrease the intensity of the chosen color. The adjustment range of each color is between 0-255, from OFF to FULL ON.
- 06) Repeatedly press the **ENTER** button to proceed to the other colors and repeat step 5.

9.2. RGBtoW

- 01) Press the **UP/DOWN** buttons to choose one of the 3 colors: RED, GREEN, BLUE.
- 02) Press the **ENTER** button to choose the desired color.
- 03) Press the **UP/DOWN** buttons to increase/decrease the intensity of the chosen color. The adjustment range of each color is between 0-255, from OFF to FULL ON.
- 04) Repeatedly press the **ENTER** button to proceed to the other colors and repeat step 3.

9.3. Calibration.R (reset)

- 01) Press the **ENTER** button to open the menu.
- 02) The display will show **PASS CODE** and you will need to insert a **key combination** which will **unlock this hidden menu**. To do so, **press the buttons in the following order: UP, DOWN, UP, DOWN, ENTER**.
- 03) The calibration settings will now be reset. The display will show **OK!**

10. Info

In this menu you can view the device's status.

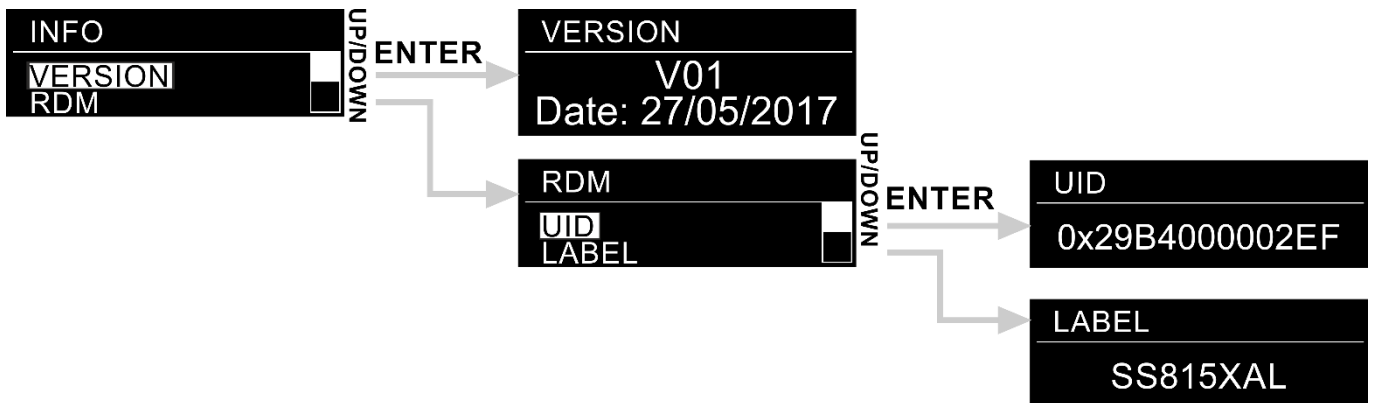

- 01) While in main menu, press the **UP/DOWN** buttons until the display shows **INFO**.
- 02) Press the **ENTER** button to open the menu.
- 03) Press the **UP/DOWN** buttons to toggle between the 2 options: **VERSION** and **RDM**.
- 04) Press the **ENTER** button to open the menu.

10.1. Version

The display will show the current software version.

10.2. RDM

- 01) Press the **UP/DOWN** buttons to toggle between **UID** and **LABEL**.
- 02) Press the **ENTER** button to view the desired RDM menu.

DMX Channels

8 channels (HSIC)

Channel 1 – Dimmer intensity

0-255 Gradual adjustment, from dark to brightest 0-100%

Channel 2 – Hue (color variations) ⚠ CH1 must be open ⚠

0-255 Gradual adjustment hue, from 0-100%

Channel 3 – Hue fine (color variations) ⚠ CH1-2 must be open ⚠

0-255 Fine adjustment hue, from 0-100%

Channel 4 – Red color saturation ⚠ CH1 must be open ⚠

0-255 Saturation adjustment, from 0-100%

Channel 5 – CCT ⚠ CH1 must be open ⚠

0-10	Not functional
11-30	2700K
31-50	3000K
51-70	3200K
71-90	3500K
91-110	4000K
111-130	4200K
131-150	4500K
151-170	5600K
171-190	6000K
191-210	6500K

211-230	7200K
231-255	8000K

Channel 6 – Strobe CH1-4 must be open

0-9	Not functional
10-99	Strobe flash frequency, from low to high frequency
100-109	Not functional
110-179	Pulse strobe, from low to high frequency
180-189	Not functional
190-255	Random strobe, from low to high frequency

Channel 7 – Zoom

0-255	Gradual adjustment zoom, from small to big
-------	--------------------------------------------

Channel 8 – Dimmer speed

0-9	Preset dimmer speed from the device's menu
10-29	Linear dimmer
30-69	Non-linear dimmer 1 (fastest)
70-129	Non-linear dimmer 2
130-189	Non-linear dimmer 3
190-255	Non-linear dimmer 4 (slowest)

10 channels (SSP)

Channel 1 – Dimmer intensity

0-255	Gradual adjustment, from dark to brightest 0-100%
-------	---------------------------------------------------

Channel 2 – Red CH1 must be open, CH7 must be closed

0-255	Gradual adjustment Red, from 0-100%
-------	-------------------------------------

Channel 3 – Green CH1 must be open, CH7 must be closed

0-255	Gradual adjustment Green, from 0-100%
-------	---------------------------------------

Channel 4 – Blue CH1 must be open, CH7 must be closed

0-255	Gradual adjustment Blue, from 0-100%
-------	--------------------------------------

Channel 5 – Amber CH1 must be open, CH7 must be closed

0-255	Gradual adjustment Amber, from 0-100%
-------	---------------------------------------

Channel 6 – Lime CH1 must be open, CH7 must be closed

0-255	Gradual adjustment Lime, from 0-100%
-------	--------------------------------------

Channel 7 – Color presets CH1 must be open

0-10	Not functional
11-20	L106
21-30	R05
31-40	L194
41-50	R54
51-60	L019
61-70	R08
71-80	R89
81-90	R86
91-100	L213

101-110	R377
111-120	R80
121-130	L202
131-140	L328
141-150	R3314
151-160	L101
161-170	L768
171-255	Not functional

Channel 8 – Strobe ⚠️ **CH1 must be open; CH2-6 or CH7 must be open** ⚠️

0-9	Not functional
10-99	Strobe flash frequency, from low to high frequency
100-109	Not functional
110-179	Pulse strobe, from low to high frequency
180-189	Not functional
190-255	Random strobe, from low to high frequency

Channel 9 – Zoom

0-255	Gradual adjustment zoom, from small to big
-------	--------------------------------------------

Channel 10 – Dimmer speed

0-9	Preset dimmer speed from the device's menu
10-29	Linear dimmer
30-69	Non-linear dimmer 1 (fastest)
70-129	Non-linear dimmer 2
130-189	Non-linear dimmer 3
190-255	Non-linear dimmer 4 (slowest)

13 channels (TOUR)

Channel 1 – Dimmer intensity

0-255	Gradual adjustment, from dark to brightest 0-100%
-------	---------------------------------------------------

Channel 2 – Red ⚠️ **CH1 must be open; CH7-8 must be closed** ⚠️

0-255	Gradual adjustment Red, from 0-100%
-------	-------------------------------------

Channel 3 – Green ⚠️ **CH1 must be open; CH7-8 must be closed** ⚠️

0-255	Gradual adjustment Green, from 0-100%
-------	---------------------------------------

Channel 4 – Blue ⚠️ **CH1 must be open; CH7-8 must be closed** ⚠️

0-255	Gradual adjustment Blue, from 0-100%
-------	--------------------------------------

Channel 5 – Amber ⚠️ **CH1 must be open; CH7-8 must be closed** ⚠️

0-255	Gradual adjustment Amber, from 0-100%
-------	---------------------------------------

Channel 6 – Lime ⚠️ **CH1 must be open; CH7-8 must be closed** ⚠️

0-255	Gradual adjustment Lime, from 0-100%
-------	--------------------------------------

Channel 7 – Color presets ⚠️ **CH1 must be open** ⚠️

0-10	Not functional
11-20	L106
21-30	R05
31-40	L194

41-50	R54
51-60	L019
61-70	R08
71-80	R89
81-90	R86
91-100	L213
101-110	R377
111-120	R80
121-130	L202
131-140	L328
141-150	R3314
151-160	L101
161-170	L768
171-255	Not functional

Channel 8 – Macros CH1 must be open

0-10	Not functional
11-30	Red 100% / Green Up / Blue 0%
31-50	Red Down / Green 100% / Blue 0%
51-70	Red 0% / Green 100% / Blue Up
71-90	Red 0% / Green Down / Blue 100%
91-110	Red Up / Green 0% / Blue 100%
111-130	Red 100% / Green 0% / Blue Down
131-150	Red 100% / Green Up / Blue Up
151-170	Red Down / Green Down / Blue 100%
171-195	Red 100% / Green 100% / Blue 100% / White 100%
196-200	2700K
201-205	3000K
206-210	3200K
211-215	3500K
216-220	4000K
221-225	4200K
226-230	4500K
231-235	5600K
236-240	6000K
241-245	6500K
246-250	7200K
251-255	8000K

Channel 9 – Strobe CH1 must be open; CH2-6 or CH7-8 must be open

0-9	Not functional
10-99	Strobe flash frequency, from low to high frequency
100-109	Not functional
110-179	Pulse strobe, from low to high frequency
180-189	Not functional
190-255	Random strobe, from low to high frequency

Channel 10 – Zoom

0-255	Gradual adjustment zoom, from small to big
-------	--------------------------------------------

Channel 11 – Built-in programs

0-40	Not functional
41-60	Auto 1
61-80	Auto 2
81-100	Auto 3
101-120	Auto 4

121-140	Auto 5
141-160	Auto 6
161-180	Auto 7
181-200	Auto 8
201-220	Auto 9
221-255	Auto 10

Channel 12 – Program speed ⚠️ **CH11 must be set between 41-255** ⚠️

0-255 Program speed adjustment, from slow to fast

Channel 13 – Dimmer speed

0-9	Preset dimmer speed from the device's menu
10-29	Linear dimmer
30-69	Non-linear dimmer 1 (fastest)
70-129	Non-linear dimmer 2
130-189	Non-linear dimmer 3
190-255	Non-linear dimmer 4 (slowest)

19 channels (TR16)

Channel 1 – Dimmer intensity

0-255 Gradual adjustment, from dark to brightest 0-100%

Channel 2 – Fine dimmer ⚠️ **CH1 must be open; CH13-14 must be closed** ⚠️

0-255 Fine dimmer adjustment, from dark to brightest 0-100%

Channel 3 – Red ⚠️ **CH1 must be open; CH13-14 must be closed** ⚠️

0-255 Gradual adjustment Red, from 0-100%

Channel 4 – Fine Red ⚠️ **CH1 and CH3 must be open; CH13-14 must be closed** ⚠️

0-255 Fine adjustment Red, from 0-100%

Channel 5 – Green ⚠️ **CH1 must be open; CH13-14 must be closed** ⚠️

0-255 Gradual adjustment Green, from 0-100%

Channel 6 – Fine Green ⚠️ **CH1 and CH5 must be open; CH13-14 must be closed** ⚠️

0-255 Fine adjustment Green, from 0-100%

Channel 7 – Blue ⚠️ **CH1 must be open; CH13-14 must be closed** ⚠️

0-255 Gradual adjustment Blue, from 0-100%

Channel 8 – Fine Blue ⚠️ **CH1 and CH7 must be open; CH13-14 must be closed** ⚠️

0-255 Fine adjustment Blue, from 0-100%

Channel 9 – Amber ⚠️ **CH1 must be open; CH13-14 must be closed** ⚠️

0-255 Gradual adjustment Amber, from 0-100%

Channel 10 – Fine Amber ⚠️ **CH1 and CH9 must be open; CH13-14 must be closed** ⚠️

0-255 Fine adjustment Amber, from 0-100%

Channel 11 – Lime ⚠️ **CH1 must be open; CH13-14 must be closed** ⚠️
 0-255 Gradual adjustment Lime, from 0-100%

Channel 12 – Fine Lime ⚠️ **CH1 and CH11 must be open; CH13-14 must be closed** ⚠️
 0-255 Fine adjustment Lime, from 0-100%

Channel 13 – Color presets ⚠️ **CH1 must be open** ⚠️

0-10	Not functional
11-20	L106
21-30	R05
31-40	L194
41-50	R54
51-60	L019
61-70	R08
71-80	R89
81-90	R86
91-100	L213
101-110	R377
111-120	R80
121-130	L202
131-140	L328
141-150	R3314
151-160	L101
161-170	L768
171-255	Not functional

Channel 14 – Macros ⚠️ **CH1 must be open** ⚠️

0-10	Not functional
11-30	Red 100% / Green Up / Blue 0%
31-50	Red Down / Green 100% / Blue 0%
51-70	Red 0% / Green 100% / Blue Up
71-90	Red 0% / Green Down / Blue 100%
91-110	Red Up / Green 0% / Blue 100%
111-130	Red 100% / Green 0% / Blue Down
131-150	Red 100% / Green Up / Blue Up
151-170	Red Down / Green Down / Blue 100%
171-195	Red 100% / Green 100% / Blue 100% / White 100%
196-200	2700K
201-205	3000K
206-210	3200K
211-215	3500K
216-220	4000K
221-225	4200K
226-230	4500K
231-235	5600K
236-240	6000K
241-245	6500K
246-250	7200K
251-255	8000K

Channel 15 – Strobe ⚠ **CH1 must be open; CH2-12 or CH13-14 must be open** ⚠

0-9	Not functional
10-99	Strobe flash frequency, from low to high frequency
100-109	Not functional
110-179	Pulse strobe, from low to high frequency
180-189	Not functional
190-255	Random strobe, from low to high frequency

Channel 16 – Zoom

0-255	Gradual adjustment zoom, from small to big
-------	--------------------------------------------

Channel 17 – Built-in programs

0-40	Not functional
41-60	Auto 1
61-80	Auto 2
81-100	Auto 3
101-120	Auto 4
121-140	Auto 5
141-160	Auto 6
161-180	Auto 7
181-200	Auto 8
201-220	Auto 9
221-255	Auto 10

Channel 18 – Program speed ⚠ **CH17 must be set between 41-255** ⚠

0-255	Program speed adjustment, from slow to fast
-------	---------------------------------------------

Channel 19 – Dimmer speed

0-9	Preset dimmer speed from the device's menu
10-29	Linear dimmer
30-69	Non-linear dimmer 1 (fastest)
70-129	Non-linear dimmer 2
130-189	Non-linear dimmer 3
190-255	Non-linear dimmer 4 (slowest)

Cleaning

Please follow the next recommendations when cleaning and inspecting lenses and reflectors:

Do not use glass or window type cleaners on lenses (glass or polymer) or reflectors.

Do not use abrasive materials such as steel wool.

Replace lenses if they contain visible damage (cracks or deep scratches) which that may impair their effectiveness.

Cleaning the Glass Lens

- 01) Remove the front cap.
- 02) Dampen a clean lint-free cloth with vinegar or household ammonia. You may also use water, but it will leave spots that can be removed by gently polishing the front lens with a clean and dry cloth.
- 03) Starting from the center, gently wipe the lens.
- 04) Re-attach the front cap.

Maintenance

The operator has to make sure that safety-related and machine-technical installations are to be inspected by an expert after every year in the course of an acceptance test.

The operator has to make sure that safety-related and machine-technical installations are to be inspected by a skilled person once a year.

The following points have to be considered during the inspection:

- 01) All screws used for installing the device or parts of the device have to be tightly connected and must not be corroded.
- 02) There may not be any deformations on housings, fixations and installation spots.
- 03) Mechanically moving parts like axles, eyes and others may not show any traces of wearing.
- 04) The electric power supply cables must not show any damages or material fatigue.

The Performer 2000 RGBAL requires almost no maintenance. However, you should keep the unit clean. Otherwise, the fixture's light output will be significantly reduced. Disconnect the mains power supply, and then wipe the cover with a damp cloth. Do not immerse in liquid. Wipe lens clean with glass cleaner and a soft cloth. Do not use alcohol or solvents.

The front lens will require weekly cleaning, as smoke-fluid tends to build up residues, reducing the light output very quickly.

Please clean internal components once a year with a light brush and vacuum cleaner.

Keep connections clean. Disconnect electric power, and then wipe the DMX and audio connections with a damp cloth. Make sure connections are thoroughly dry before linking equipment or supplying electric power.

Replacing the Fuse

Power surges, short-circuit or inappropriate electrical power supply may cause a fuse to burn out. If the fuse burns out, the product will not function whatsoever. If this happens, follow the directions below:

- 01) Unplug the unit from electric power source.
- 02) Insert a flat-head screwdriver into a slot in the fuse cover. Turn the screwdriver to the left, at the same time gently push a bit (Turn and Push). The fuse will come out.
- 03) Remove the used fuse. If brown or unclear, it is burned out.
- 04) Insert the replacement fuse into the holder where the old fuse was. Reinsert the fuse cover. Be sure to use a fuse of the same type and specification. See the product specification label for details.

Troubleshooting

This troubleshooting guide is meant to help solve simple problems.

If a problem occurs, carry out the steps below in sequence until a solution is found. Once the unit operates properly, do not carry out following steps.

No Light

If the light effect does not operate properly, refer servicing to a technician.

Suspect three potential problem areas as: the power supply, the LEDs, the fuse.

- 01) Power supply. Check if the unit is plugged into an appropriate power supply.
- 02) The LEDs. Return the Performer to your Showtec dealer.
- 03) The fuse. Replace the fuse. See page 32 for replacing the fuse.
- 04) If all of the above appears to be O.K., plug the unit in again.
- 05) If you are unable to determine the cause of the problem, do not open the Performer, as this may damage the unit and the warranty will become void.
- 06) Return the device to your Showtec dealer.

No Response to DMX

Suspect the DMX cable or connectors, a controller malfunction, a light effect DMX card malfunction.

- 01) Check the DMX setting. Make sure that DMX addresses are correct.
- 02) Check the DMX cable: Unplug the unit; change the DMX cable; then reconnect to electrical power. Try your DMX control again.
- 03) Determine whether the controller or light effect is at fault. Does the controller operate properly with other DMX products? If not, take the controller in for repair. If so, take the DMX cable and the light effect to a qualified technician.

Problem	Probable cause(s)	Solution
One or more fixtures do not function at all	No power to the fixture	<ul style="list-style-type: none"> • Check if power is switched on and cables are plugged in
	Primary fuse blown	<ul style="list-style-type: none"> • Replace fuse
Fixtures reset correctly, but all respond erratically or not at all to the controller	The controller is not connected.	<ul style="list-style-type: none"> • Connect controller
	3-pin/5-pin XLR Out of the controller does not match XLR Out of the first fixture on the link (i.e. signal is reversed)	<ul style="list-style-type: none"> • Install a phase reversing cable between the controller and the first fixture on the link
Fixtures reset correctly, but some respond erratically or not at all to the controller	Poor data quality	<ul style="list-style-type: none"> • Check data quality. If much lower than 100 percent, the problem may be a bad data link connection, poor quality or broken cables, missing termination plug, or a defective fixture disturbing the link
	Bad data link connection	<ul style="list-style-type: none"> • Inspect connections and cables. Correct poor connections. Repair or replace damaged cables
	Data link not terminated with 120 Ohm termination plug	<ul style="list-style-type: none"> • Insert termination plug in output jack of the last fixture on the link
	Incorrect addressing of the fixtures	<ul style="list-style-type: none"> • Check address setting
	One of the fixtures is defective and disturbs data transmission on the link	<ul style="list-style-type: none"> • Bypass one fixture at a time until normal operation is restored: unplug both connectors and connect them directly together. • Have the defective fixture serviced by a qualified technician
	3-pin/5-pin XLR Out on the fixtures does not match (pins 2 and 3 reversed)	<ul style="list-style-type: none"> • Install a phase-reversing cable between the fixtures or swap pin 2 and 3 in the fixture that behaves erratically
No light or LEDs cut out intermittently	Fixture is too hot	<ul style="list-style-type: none"> • Allow the fixture to cool down • Clean the fan • Make sure air vents in control panel and the front lens are not blocked • Turn up the air conditioning
	LEDs damaged	<ul style="list-style-type: none"> • Disconnect the fixture and return it to your dealer
	The power supply settings do not match local AC voltage and frequency	<ul style="list-style-type: none"> • Disconnect fixture. Check settings and correct if necessary

Product Specifications

Model:	Showtec Performer 2000 RGBAL
Input voltage:	100-240V AC, 50/60Hz
Power consumption:	230W (full output)
DMX linking:	30pcs
Fuse:	T6,3AL/250V
Dimensions:	455 x 285 x 435 mm (LxWxH)
Weight:	7,5 kg
Operating and Programming:	
Signal pin OUT:	Pin 1 (earth), pin 2 (-), pin 3 (+)
DMX Mode:	8, 10, 13, 19 channels
Signal input:	3-pin/5-pin XLR IN
Signal output:	3-pin/5-pin XLR OUT
Electro-mechanical effects:	
Light source:	1 x 240W LED Array 5-in-1
Light output:	55000 Lux @1m (15° zoom)
Max flux:	5300 Lumen
Drive current:	1,5A
Motorized zoom:	15-45°
Field angle:	25-76°
Dimmer:	0-100%
Dimming curves:	Dimm4 technology, 4 presets
Dimmer resolution:	16bit
Strobe:	0-25Hz
Peak intensity:	41900cd
Color rendering:	>90Ra (2700-4500K), >85Ra (5600-8000K)
Color temperature:	2700-8000K
Refresh rate:	600Hz to 25kHz
Housing:	Extruded aluminum & flame retardant plastic
Color:	Black
Control protocol:	RDM, DMX-512
DMX control:	via standard DMX controller
Onboard:	LCD display for easy setup
Control:	Stand-alone, Master/Slave, DMX-512/RDM
Connections:	Pro power IN/OUT & dedicated data connector
IP rating:	IP20
Cooling:	Internal fan
Max. ambient temperature t_a :	40°C
Max. housing temperature t_b :	65°C
Minimum distance:	
Minimum distance from flammable surfaces:	0,5 m
Minimum distance to lighted object:	1 m

Design and product specifications are subject to change without prior notice.



Website: www.Showtec.info

Email: service@highlite.nl

Dimensions

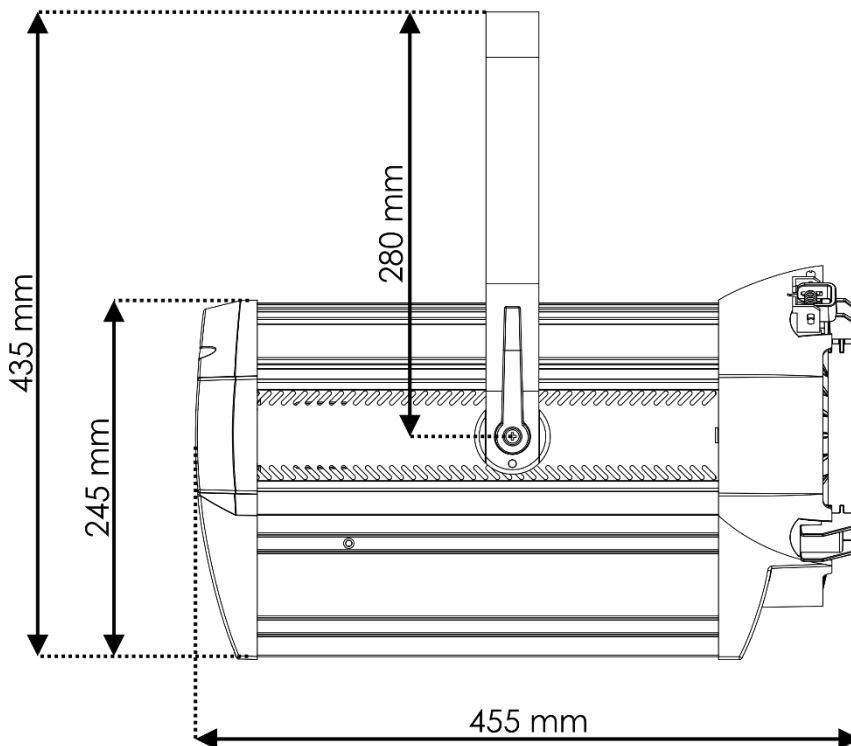
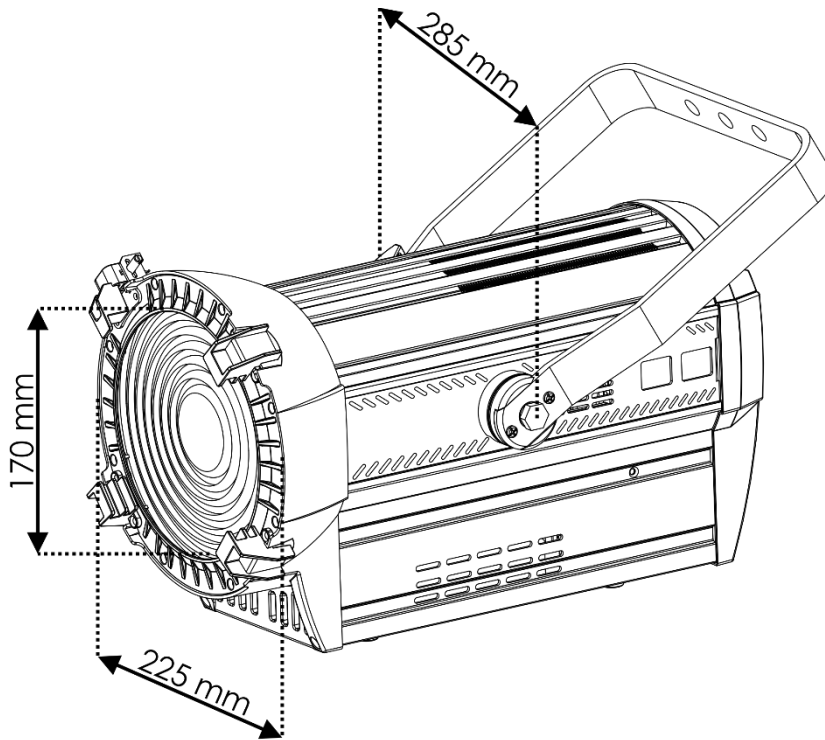



©2017 Showtec