

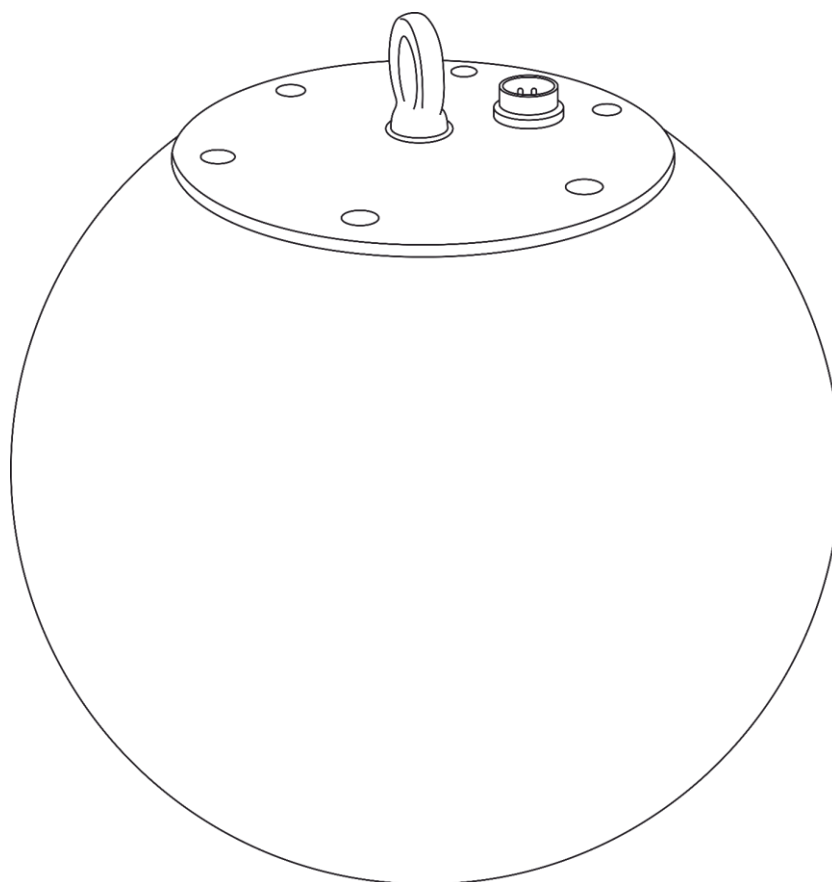

**MANUAL**



**ENGLISH**

# **Illumilift LED Sphere 35 cm V1**

**Order code: 41168**

**Table of contents**

---

**Warning** .....2  
    Safety Instructions .....3  
    Operating Determinations .....4  
    Rigging .....5  
    Connection with the mains.....6  
    Return Procedure .....6  
    Claims.....6

**Description of the device**.....7  
    LED Sphere .....7

**Installation**.....7

**Setup and Operation** .....8

**Maintenance** .....8

**Troubleshooting** .....8  
    No Light .....8  
    No Response to DMX.....8

**Product Specifications**.....10

**Dimensions**.....10

## Warning



**For your own safety, please read this user manual carefully  
before your initial start-up!**



**Power the device up ONLY when the LED sphere IS INSTALLED.  
Power the device up ONLY when the controller is in VERTICAL position.**



**The built-in winch system resets itself upon each start-up. If the controller is not in vertical position and/or the LED sphere is not installed, it may result in twisting of the cable that may cause damage to the built-in winch system and the warranty will become void.**



**Before powering the Illumilift up, always make sure that:**



- the controller is positioned VERTICALLY.
- the LED sphere is installed and secured by means of the safety eye.
- the cable tie, keeping the hoisting cable in position, is removed.
- the hoisting cable is not loose.
- the maximum cable load (2 kg) is not exceeded.
- the movement of the Illumilift is not interrupted in any way.



## Unpacking Instructions

Immediately upon receiving this product, carefully unpack the carton and check the contents to ensure that all parts are present, and have been received in good condition. Notify the dealer immediately and retain packing material for inspection if any parts appear damaged from shipping or the carton itself shows signs of mishandling. Save the carton and all packing materials. In the event that a fixture must be returned to the factory, it is important that the fixture be returned in the original factory box and packing.

## Your shipment includes:

- Showtec Illumilift LED Sphere 35 cm with 5-pin connector
- User manual

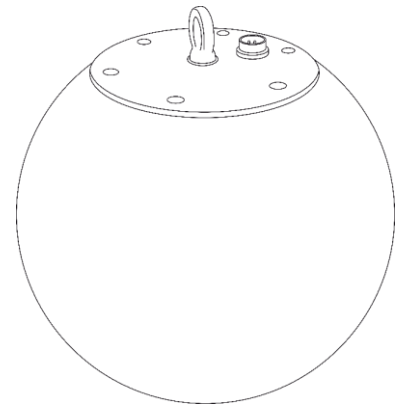

## LED Expected Lifespan

LEDs gradually decline in brightness over time. HEAT is the dominant factor that leads to the acceleration of this decline. Packaged in clusters, LEDs exhibit higher operating temperatures than in ideal or singular optimum conditions. For this reason, when all color LEDs are used at their fullest intensity, life of the LEDs is significantly reduced. If improving the lifespan is of higher priority, place care in providing for lower operational temperatures. This may include climatic-environmental and the reduction of overall projection intensity.



**CAUTION!**  
**Keep this device away from rain and moisture!  
Unplug mains lead before opening the housing!**



## Safety Instructions

Every person involved with the installation, operation and maintenance of this device has to:

- be qualified
- follow the instructions of this manual

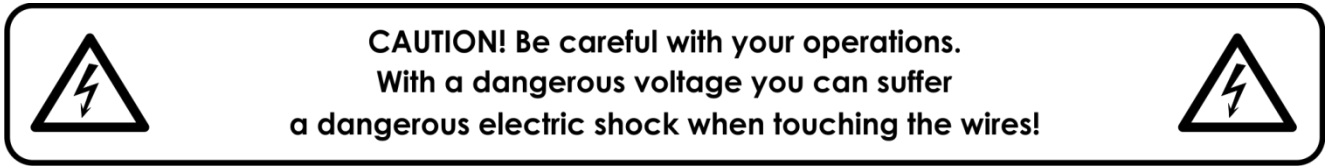

Before the initial start-up, please make sure that there is no damage caused by transportation.

Should there be any, consult your dealer and do not use the device.

To maintain perfect condition and to ensure a safe operation, it is absolutely necessary for the user to follow the safety instructions and warning notes contained in this manual.

Please consider that damages caused by manual modifications to the device are not subject to warranty.

This device contains no user-serviceable parts. Refer servicing to qualified technicians only.

### IMPORTANT:

The manufacturer will not accept liability for any resulting damages caused by the non-observance of this manual or any unauthorized modification to the device.

- Never let the power cord come into contact with other cables! Handle the power cord and all connections with the mains with particular caution!
- Never modify, bend, mechanically strain, put pressure on, pull or heat up the power cord.
- Never strain the cable. There must always be sufficient cable going to the device. Otherwise, the cable will be damaged, which can cause serious damage.
- Never remove warning or informative labels from the unit.
- Never use anything to cover the ground contact.
- Never place any material over the LEDs.
- Never look directly into the light source.
- Never leave any cables lying around.
- Never use the device during thunderstorms, unplug the device immediately.
- Never leave various parts of the packaging (plastic bags, polystyrene foam, nails, etc.) within children's reach, as they are potential sources of danger.
- Do not insert objects into air vents.
- Do not open the device and do not modify the device.
- Do not connect this device to a dimmer pack.
- Do not switch the device on and off in short intervals, as this will reduce the device's life.
- Do not touch the device's housing bare-handed during its operation.
- Do not shake the device. Avoid brute force when installing or operating the device.
- Do not stand under the Illumilift, once it has been mounted.
- Only use the device indoors, avoid contact with water or other liquids.
- Only operate the device after having checked if the housing is firmly closed and all screws are tightly fastened.
- Only operate the device after having familiarized with its functions.
- Avoid flames and do not put close to flammable liquids or gases.
- Always allow a free air space of at least 50 cm around the unit for ventilation.
- Always disconnect power from the mains, when device is not used or before cleaning! Only handle the power cord holding it by the plug. Never pull out the plug by tugging the power cord.
- Make sure that the device is not exposed to extreme heat, moisture or dust.
- Make sure that the available voltage is not higher than stated on the rear panel.
- Make sure that the power cord and the hoisting cable are never crimped or damaged. Check the device, the power cord and the hoisting cable from time to time.

- Make sure that the core diameter of extension cords and power cords is sufficient for the required power consumption of the device.
- Make sure that the movement of the Illumilift is not interrupted in any way by decoration parts, etc.
- Make sure that the Illumilift cannot start swinging due to air streams, etc. The LED sphere and the winch system should be hung and operated absolutely vibration-free.
- Make sure that there is enough separation between the Illumilift and the objects installed below.
- Regularly examine whether the link and the hoist have any deformations. If they do, immediately detach the LED sphere and do not use the Illumilift.
- If the LEDs are obviously damaged, they need to be replaced to prevent their functions from being impaired, due to cracks or deep scratches.
- If the external cable is damaged, it has to be replaced by a qualified technician.
- If device was dropped or struck, disconnect mains power supply immediately. Have a qualified engineer inspect for safety before operating.
- If the device has been exposed to drastic temperature fluctuation (e.g. after transportation), do not switch it on immediately. The arising condensation water might damage your device. Leave the device switched off until it has reached room temperature.
- If your Showtec device fails to work properly, discontinue the use immediately. Pack the unit securely (preferably in the original packing material), and return it to your Showtec dealer for service.
- For adult use only. The device must be installed beyond the reach of children. Never leave the unit running unattended.
- Never attempt to bypass the thermostatic switch or fuses.
- For replacement use fuses of same type and rating only.
- The user is responsible for correct positioning and operating of the device. The manufacturer will not accept liability for damages caused by the misuse or incorrect installation of this device.
- This device falls under protection class I. Therefore it is essential to connect the yellow/green conductor to earth.
- Repairs, servicing and electric connection must be carried out by a qualified technician.
- WARRANTY: Till one year after date of purchase.

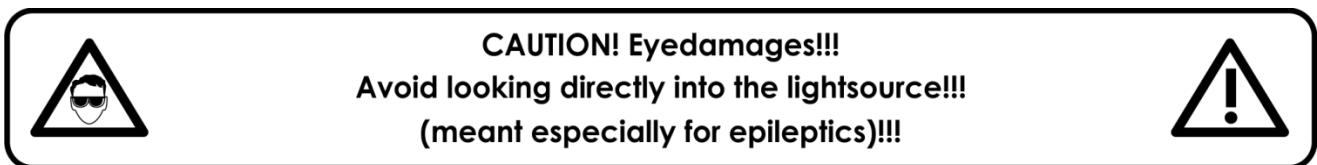

### Operating Determinations

- This device is not designed for permanent operation. Consistent operation breaks will ensure that the device will serve you for a long time without defects.
- The minimum distance between light output and the illuminated surface must be bigger than 0,5 meter.
- To eliminate wear and improve lifespan, during periods of non-use, completely disconnect from power via breaker or by unplugging.
- The maximum ambient temperature  $t_a = 40\text{ °C}$  must never be exceeded.
- The relative humidity must not exceed 50 % with an ambient temperature of 40 °C.
- If this device is operated in any other way than the one described in this manual, the product may suffer damages and the warranty becomes void.
- Any other operation may lead to dangers like short-circuit, burns, electric shock, crash, etc.

*You endanger your own safety and the safety of others!*

### Rigging

Please follow the European and national guidelines concerning rigging, trussing and all other safety issues.

*Do not attempt the installation yourself !*

*Always let the installation be carried out by an authorized dealer !*

### Procedure:

- If the Illumilift is lowered from the ceiling or high joists, professional trussing systems have to be used.
- The Illumilift must never be fixed swinging freely in the room.
- The installation must always be secured with a safety attachment, e.g. an appropriate safety net or a safety cable that can hold a minimum point load of 10 times the device's load (e.g. maximum load: 3 kg = point load: 30 kg).
- When rigging, derigging or servicing the device, always make sure, that the area below the installation place is blocked and staying in the area is forbidden.

*Improper installation can cause serious injuries and/or damage of property!*

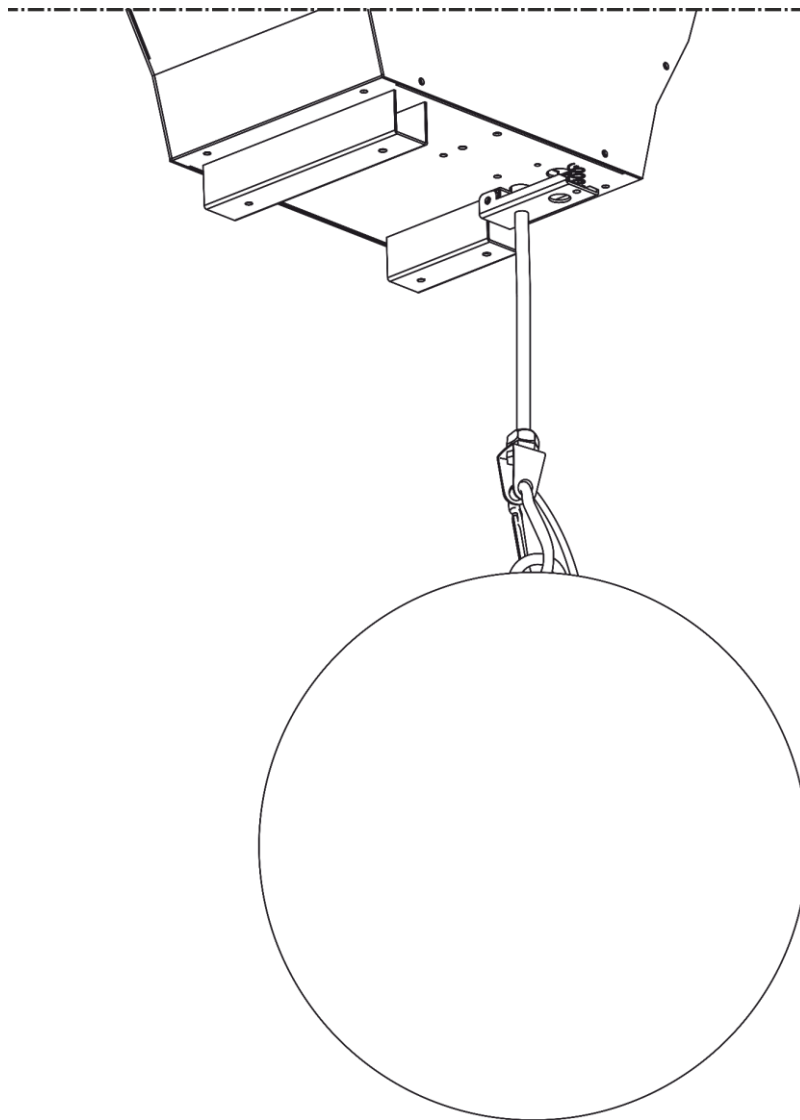

The Illumilift LED Sphere can be mounted to the Illumilift RGBW (41165) or the Illumilift RGBW Turbo (41166).

*Improper installation can cause serious injuries and/or damage of property!*

**Connection with the mains**

Connect the device to the mains with the power-plug.  
Always check if the right color cable is connected to the right place.

International	EU Cable	UK Cable	US Cable	Pin
L	BROWN	RED	YELLOW/COPPER	PHASE
N	BLUE	BLACK	SILVER	NEUTRAL
	YELLOW/GREEN	GREEN	GREEN	PROTECTIVE GROUND

*Make sure that the device is always properly connected to the earth!*

*Improper installation can cause serious injuries and/or damage of property!*



** Return Procedure **

Returned merchandise must be sent prepaid and in the original packing, call tags will not be issued. Package must be clearly labeled with a Return Authorization Number (RMA number). Products returned without an RMA number will be refused. Highlite will not accept the returned goods or any responsibility. Call Highlite 0031-455667723 or mail [offersales@highlite.com](mailto:offersales@highlite.com) and request an RMA prior to shipping the fixture. Be prepared to provide the model number, serial number and a brief description of the cause for the return. Be sure to properly pack fixture, any shipping damage resulting from inadequate packaging is the customer's responsibility. Highlite reserves the right to use its own discretion to repair or replace product(s). As a suggestion, proper UPS packing or double-boxing is always a safe method to use.

**Note: If you are given an RMA number, please include the following information on a piece of paper inside the box:**

- 01) Your name
- 02) Your address
- 03) Your phone number
- 04) A brief description of the symptoms

**Claims**

The client has the obligation to check the delivered goods immediately upon delivery for any shortcomings and/or visible defects, or perform this check after our announcement that the goods are at their disposal. Damage incurred in shipping is the responsibility of the shipper; therefore the damage must be reported to the carrier upon receipt of merchandise.

It is the customer's responsibility to report and submit claims with the shipper in the event that a fixture is damaged due to shipping. Transportation damage has to be reported to us within one day after receipt of the delivery.

Any return shipment has to be made post-paid at all times. Return shipments must be accompanied with a letter defining the reason for return shipment. Non-prepaid return shipments will be refused, unless agreed otherwise in writing.

Complaints against us must be prepared in writing or sent by fax within 10 working days after receipt of the invoice. After this period complaints will not be handled anymore.

Complaints will only then be considered if the client has so far complied with all parts of the agreement, regardless of the agreement from which the obligation is resulting.

## Description of the device

### Features

The Illumilift LED Sphere 25 cm with high output and great effects.

- Power consumption: 18 W
- LED Control: RGBW
- IP rating: IP22
- Connections: special 5-pin connector for connecting the power cable from Illumilift RGBW (41165) or the Illumilift RGBW Turbo (41166)
- Dimensions: Ø350 mm
- Weight (LED sphere): 1,56 kg

### Optional accessories

[41165](#) – Illumilift RGBW

[41166](#) – Illumilift RGBW Turbo

### LED Sphere

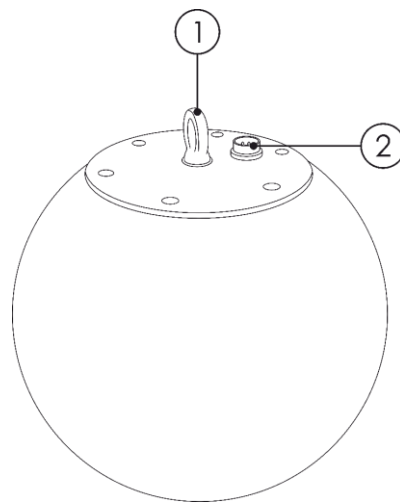

Fig. 01

01) Safety eye

02) 5-pin signal connector IN

### Installation

Remove all packing materials from the Illumilift LED Sphere. Check if all foam and plastic padding is removed. Connect all cables.

**Do not supply power before the whole system is set up and connected properly.**

**Always disconnect from electric mains power supply before cleaning or servicing.**

**Damages caused by non-observance are not subject to warranty.**

- ⚠ **Power the device up ONLY when the LED sphere IS INSTALLED.**
- ⚠ **Power the device up ONLY when the controller is in VERTICAL position.**

- ⚠ **The built-in winch system resets itself upon each start-up. If the controller is not in vertical position and/or the LED sphere is not installed, it may result in twisting of the cable that may cause damage to the built-in winch system and the warranty will become void.**

Before powering the Illumilift up, always make sure that:

- ⚠
  - the controller is positioned VERTICALLY.
  - the LED sphere is installed and secured by means of the safety eye.
  - the cable tie, keeping the hoisting cable in position, is removed.
  - the hoisting cable is not loose.
  - the maximum cable load (2 kg) is not exceeded.
  - the movement of the Illumilift is not interrupted in any way.



## Setup and Operation

---

Follow the directions below, as they pertain to your preferred operation mode.

Before plugging the unit in, always make sure that the power supply matches the product specification voltage. Do not attempt to operate a 120 V specification product on 230 V power, or vice versa. Connect the device to the main power supply.

## Maintenance

---

The operator has to make sure that safety-related and machine-technical installations are to be inspected by an expert after every year in the course of an acceptance test.

The operator has to make sure that safety-related and machine-technical installations are to be inspected by a skilled person once a year.

The following points have to be considered during the inspection:

- 01) All screws used for installing the device or parts of the device have to be tightly connected and must not be corroded.
- 02) There may not be any deformations on housings, fixations and installation spots.
- 03) Mechanically moving parts like axles, eyes and others may not show any traces of wearing.
- 04) The electric power supply cables must not show any damages or material fatigue.

The Illumilift LED Sphere 25 requires almost no maintenance. However, you should keep the unit clean. Otherwise, the fixture's light output will be significantly reduced. Disconnect the mains power supply, and then wipe the cover with a damp cloth. Do not immerse in liquid. Do not use alcohol or solvents. The cooling fans should be cleaned monthly, with a soft brush.

Please clean internal components once a year with a light brush and vacuum cleaner.

Keep connections clean. Disconnect electric power, and then wipe the DMX connections with a damp cloth. Make sure connections are thoroughly dry before linking equipment or supplying electric power.

## Troubleshooting

---

This troubleshooting guide is meant to help solve simple problems.

If a problem occurs, carry out the steps below in sequence until a solution is found. Once the unit operates properly, do not carry out following steps.

### No Light

If the light effect does not operate properly, refer servicing to a technician.

Suspect two potential problem areas as: the power cable, the LEDs.

- 01) Power supply. Check if the 5-pin power cable from the Illumilift RGBW (41165) or the Illumilift RGBW Turbo (41166) is properly plugged into LED sphere.
- 02) The LEDs. Return the Illumilift to your Showtec dealer.
- 03) If all of the above appears to be O.K., plug the unit in again.
- 04) If you are unable to determine the cause of the problem, do not open the Illumilift, as this may damage the unit and the warranty will become void.
- 05) Return the device to your Showtec dealer.

### No Response to DMX

Suspect the DMX cable or connectors, a controller malfunction, a light effect DMX card malfunction.

- 01) Check the DMX setting. Make sure that DMX addresses are correct.
- 02) Check the DMX cable: Unplug the unit; change the DMX cable; then reconnect to electrical power. Try your DMX control again.
- 03) Determine whether the controller or light effect is at fault. Does the controller operate properly with other DMX products? If not, take the controller in for repair. If so, take the DMX cable and the light effect to a qualified technician.

Problem	Probable cause(s)	Remedy
One or more fixtures do not function at all.	No power to the fixture.	<ul style="list-style-type: none"> <li>• Check if power is switched on and cables are plugged in.</li> </ul>
	Primary fuse blown.	<ul style="list-style-type: none"> <li>• Replace fuse.</li> </ul>
Fixtures reset correctly, but all respond erratically or not at all to the controller.	The controller is not connected.	<ul style="list-style-type: none"> <li>• Connect controller.</li> </ul>
	3-pin XLR Out of the controller does not match XLR In of the first fixture on the link (i.e. signal is reversed).	<ul style="list-style-type: none"> <li>• Install a phase reversing cable between the controller and the first fixture on the link.</li> </ul>
Fixtures reset correctly, but some respond erratically or not at all to the controller.	Poor data quality.	<ul style="list-style-type: none"> <li>• Check data quality. If much lower than 100 percent, the problem may be a bad data link connection, poor quality or broken cables, missing termination plug, or a defective fixture disturbing the link.</li> </ul>
	Bad data link connection.	<ul style="list-style-type: none"> <li>• Inspect connections and cables. Correct poor connections. Repair or replace damaged cables.</li> </ul>
	Data link not terminated with 120 Ohm termination plug.	<ul style="list-style-type: none"> <li>• Insert termination plug in output jack of the last fixture on the link.</li> </ul>
	Incorrect addressing of the fixtures.	<ul style="list-style-type: none"> <li>• Check address setting.</li> </ul>
	One of the fixtures is defective and disturbs data transmission on the link.	<ul style="list-style-type: none"> <li>• Bypass one fixture at a time until normal operation is regained: unplug both connectors and connect them directly together.</li> <li>• Have the defective fixture serviced by a qualified technician.</li> </ul>
	3-pin XLR Out on the fixtures does not match (pins 2 and 3 reversed).	<ul style="list-style-type: none"> <li>• Install a phase-reversing cable between the fixtures or swap pin 2 and 3 in the fixture, that behaves erratically.</li> </ul>
No light or LEDs cut out intermittently.	Fixture is too hot.	<ul style="list-style-type: none"> <li>• Allow fixture to cool.</li> <li>• Clean the fan.</li> <li>• Make sure air vents are not blocked.</li> <li>• Turn up the air conditioning.</li> </ul>
	LEDs damaged.	<ul style="list-style-type: none"> <li>• Disconnect fixture and return to your dealer.</li> </ul>
	The power supply settings do not match local AC voltage and frequency.	<ul style="list-style-type: none"> <li>• Disconnect fixture. Check settings and correct if necessary.</li> </ul>

**Product Specifications**

Model:	Showtec Illumilift RGBW Turbo
Power consumption:	18 W
LED control:	RGBW
Dimensions:	Ø350 mm
Weight:	1,56 kg
<b>Operating and Programming:</b>	
Power/ Signal IN	special 5-pin connector for connecting the power cable from Illumilift RGBW (41165) or the Illumilift RGBW Turbo (41166)
IP rating:	IP22
Max. ambient temperature $t_a$ :	40 °C
Max. housing temperature $t_B$ :	70 °C
<b>Minimum distance:</b>	
Minimum distance from flammable surfaces:	0,5 m
Minimum distance to lighted object:	0,5 m

Design and product specifications are subject to change without prior notice.



Website: [www.Showtec.info](http://www.Showtec.info)

Email: [service@highlite.com](mailto:service@highlite.com)

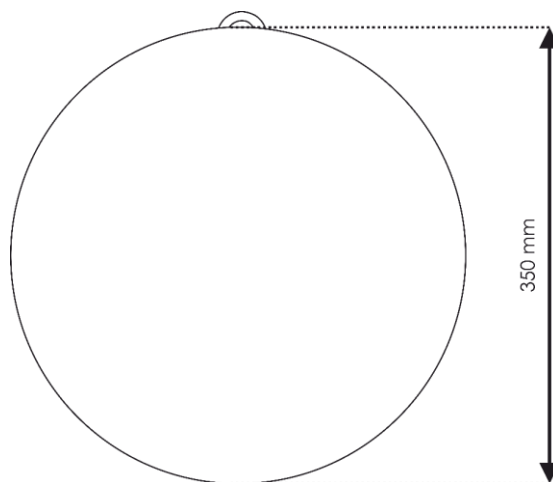
**Dimensions**



©2019 Showtec